

Valera



HOSPITALITY

Valera 
HOSPITALITY





HAIRDRYERS FOR HEAVY DUTY USE

10

Hairdryers for public areas with high frequency of users
Haartrockner für öffentliche Anlagen mit hoher Nutzungsfrequenz
Asciugacapelli per impianti pubblici con alta frequenza di utenti
Sèche-cheveux pour structures publiques
avec grande fréquence d'utilisation

HAIRDRYERS FOR MEDIUM DUTY USE - PROFESSIONAL HAIRDRYERS

14

Hairdryers for small public places with low frequency
of users and for hotel rooms
Haartrockner für kleinere öffentliche Einrichtungen
mit niedriger Nutzungsfrequenz und für Gästezimmer
Asciugacapelli per piccoli impianti pubblici con bassa frequenza
di utenti e per camere d'albergo
Sèche-cheveux pour petites installations publiques
avec basse fréquence d'utilisation et pour chambres d'hôtels

HAIRDRYERS FOR HOTEL ROOMS

22

Haartrockner für Gästezimmer
Asciugacapelli per camere d'albergo
Sèche-cheveux pour chambres d'hôtels

AUTOMATIC HAND DRYER

52

Automatischer Händetrockner
Asciugamani automatico
Sèche-mains automatique mural

MAGNIFYING MIRRORS AND SOAP DISPENSERS

54

Vergrößerungsspiegel und Seifenspender
Specchi ingranditori ed erogatori di sapone
Miroirs agrandisseurs et distributeurs de savon



SWISS QUALITY BY **VALERA**

NUMMER 1 IN HOTEL HAIRDRYERS

VALERA meets the highest demands of top-class hotels in terms of safety, durability, environmental compatibility, aesthetics and comfort. Every year VALERA, the Swiss Hair Specialist since 1955, provides hairdryers to more than 150,000 hotel rooms worldwide.

VALERA GUARANTEES:

IN-HOUSE - All hair and hand dryers are developed, designed and produced in its own manufacturing plant in Ligornetto/Switzerland.

SAFETY - All VALERA appliances meet the highest of safety standards and carry the test symbols of internationally renowned institutes. VALERA received ISO 9001 certification as early as 1995.

LOW CONSUMPTION - VALERA hair dryers make energy-saving settings possible, have a long life and achieve high drying rates even at low wattages.

SUSTAINABILITY - The exclusive use of ripple-shaped (not spiral) wires of the heating elements guarantees longer life, optimum quality and safety of hairdryers. They are manufactured from materials 95% of which can be recycled and they do not contain any hazardous or dangerous substances (RoHS directive). VALERA is a member of the Swiss Recycling Society S.EN.S.*.

* "Stiftung Entsorgung Schweiz": Swiss Society for the Recycling of electrical and electronic appliances.

NUMMER 1 IN HOTELHAARTROCKNERN

VALERA bedient höchste Ansprüche der Spitzenhotellerie an Sicherheit, Langlebigkeit, Umweltfreundlichkeit, Ästhetik und Komfort. Jedes Jahr liefert VALERA, der Schweizer Haarspezialist seit 1955, Haartrockner für weltweit mehr als 150.000 Hotelzimmer.

VALERA GARANTIERT:

HAUSEIGENE PRODUKTION - Alle Haar- und Handtrockner werden im eigenen Werk in Ligornetto in der Schweiz entwickelt, designt und produziert.

SICHERHEIT - Alle VALERA Geräte entsprechen höchsten Sicherheitsstandards, tragen Prüfzeichen international anerkannter Institute. VALERA erhielt bereits 1995 die Zertifizierung nach ISO 9001.

NIEDRIGER VERBRAUCH - VALERA Haartrockner ermöglichen energiesparende Einstellungen, haben eine lange Lebensdauer und erzielen hohe Trocknungsraten auch bei niedriger Wattleistung.

NACHHALTIGKEIT - Die ausschliessliche Verwendung wellenförmig (nicht spiralförmig) geformter Heizdrähte sorgt für maximale Lebensdauer, Qualität und Sicherheit der Haartrockner. Diese sind aus zu 95% recyclingfähigen Materialien hergestellt und enthalten keine gefährlichen Substanzen (RoHS Richtlinie). VALERA ist Mitglied der Schweizer Recycling-Gesellschaft S.EN.S.*.

* "Stiftung Entsorgung Schweiz": Schweizer Gesellschaft für das Recycling elektrischer und elektronischer Geräte.



NUMERO 1 DEGLI ASCIUGACAPELLI DA ALBERGO

VALERA soddisfa le esigenze più elevate degli alberghi in termini di sicurezza, durata, ecocompatibilità, estetica e comfort. Ogni anno VALERA, lo specialista Svizzero dei capelli dal 1955, fornisce asciugacapelli a oltre 150.000 camere d'albergo in tutto il mondo.

VALERA GARANTISCE:

PRODUZIONE PROPRIA - Tutti gli asciugacapelli e asciugamani elettrici sono sviluppati, progettati e prodotti nel proprio stabilimento di Ligornetto in Svizzera.

SICUREZZA - Tutti gli apparecchi VALERA soddisfano i massimi standard di sicurezza e sono contrassegnati con i marchi di istituti internazionali riconosciuti. Nel 1995 VALERA aveva già ottenuto la certificazione secondo ISO 9001.

BASSO CONSUMO - Gli asciugacapelli VALERA permettono una regolazione per il risparmio di energia, hanno una lunga durata e raggiungono prestazioni di asciugatura elevate anche a bassa potenza.

SOSTENIBILITÀ - L'uso esclusivo di resistenze ad onda (e non a spirale) garantisce una durata maggiore, la massima qualità e sicurezza degli asciugacapelli. Essi sono realizzati con materiali riciclabili al 95% e non contengono sostanze pericolose (direttiva RoHS). VALERA è membro della Fondazione Svizzera Smaltimento S.EN.S.*

* "Stiftung Entsorgung Schweiz": Società Svizzera per il riciclaggio di apparecchi elettrici ed elettronici.

N° 1 DES SÈCHE-CHEVEUX DANS L'HÔTELLERIE

VALERA répond aux exigences plus élevées des hôteliers en matière de sécurité, longévité, respect de l'environnement, esthétique et confort. Chaque année VALERA, le spécialiste Suisse des cheveux depuis 1955, fournit des sèche-cheveux à plus de 150.000 chambres d'hôtel dans le monde.

VALERA GARANTIT:

FABRICATION INTERNE - VALERA conçoit, dessine et produit tous ses sèche-cheveux et sèche-mains dans son usine de Ligornetto en Suisse.

SÉCURITÉ - Tous les appareils VALERA sont conformes aux normes de sécurité les plus pointues et portent les marques de contrôle d'instituts de renommée internationale. VALERA jouit depuis 1995 de la certification ISO 9001.

BASSE CONSOMMATION - Les sèche-cheveux VALERA permettent des réglages d'économie d'énergie, ont une longue durée de vie et une performance de séchage élevée même à faible puissance.

POLITIQUE ÉCOLOGIQUE - L'utilisation exclusive de résistances à filaments ondulés (et non pas à spirale) garantit une durée de vie plus longue, une qualité supérieure et une sécurité accrue des sèche-cheveux, qui sont réalisés avec des matériaux recyclables au 95 % et ne contiennent aucune substance nocive (directive RoHS). VALERA est membre de la « Schweizer Recycling-Gesellschaft S.EN.S. »*

* « Stiftung Entsorgung Schweiz » : société suisse de recyclage des appareils électriques et électroniques.

TECHNOLOGY BY **VALERA**



ENDURO BRUSHLESS DIGITAL BLDC MOTOR

In BLDC motors, four powerful Neodymium Iron Boron magnets replace the graphite carbon brushes used in conventional motors, which rub against the rotor and wear out. This guarantees a service life of up to 10,000 hours (5 times longer than AC motors), a lighter weight and the prevention of environmental pollution through carbon dust emission.

MOTOR ENDURO BRUSHLESS DIGITAL BLDC

In BLDC-Motoren ersetzen vier starke Neodym Eisen Bor Magnete die der Abnutzung durch Reibung am Rotor unterliegenden Graphitkohlebürsten herkömmlicher Motoren. Das garantiert eine Betriebszeit von bis zu 10.000 Stunden (5-mal länger als AC-Motoren), ein geringeres Gewicht sowie die Vermeidung von Umweltbelastung durch Kohlenstaub-Emission.



LONG-LIFE AC UNIVERSAL MOTOR

AC (Alternated Current) Universal Motors are collector motors, which are typically used in real professional hairdryers. They produce a high air flow and pressure and have a very long life. The expected average life of this motor is approx. 2000 hours.

KOLLEKTORMOTOR AC LONG-LIFE

AC-Wechselstrom-Kollektormotoren kommen traditionell in leistungsfähigen professionellen Haartrocknern zum Einsatz. Sie produzieren einen hohen Luftstrom und -druck und sind besonders langlebig. Durchschnittliche Lebensdauer: etwa 2000 Stunden.



LONG-LIFE DC-PRO MOTOR

Ultralight DC-PRO motors are a new generation of 'direct current' motors. Thanks to the exclusive ventilation technology of VALERA professional hairdryers, DC-PRO motors produce a very high air flow and pressure, very similar to the classic but heavier AC motors. This allows the use of thin professional styling nozzles. The expected average life of this motor is approx. 1200 hours.

MOTOR DC-PRO LONG-LIFE

Die ultraleichten DC-PRO-Motoren sind eine neue Generation von Gleichstrom-Motoren. Dank der exklusiven Lüfertechnologie der professionellen VALERA Haartrockner produzieren DC-PRO Motoren einen sehr hohen Luftstrom und -druck ähnlich dem der klassischen, aber schwereren AC-Motoren. Dies ermöglicht die Verwendung von schmalen professionellen Ondulierdüsen. Durchschnittliche Lebensdauer: etwa 1200 Stunden.



COMPACT DC MOTOR

DC motors are "direct current" motors. Their ultralight weight and particularly small dimension allow very compact designs of hairdryers. Valera has selected the highest quality of such motors for its classical compact hotel hairdryers. The expected average life of this motor is approx. 800 h.

KOMPAKTER DC-MOTOR

DC-Motoren sind Gleichstrom-Motoren. Ihr ultraleichtes Gewicht und besonders kleine Abmessungen ermöglichen sehr kompakte Haartrockner-Designs. VALERA hat für seine klassischen kompakten Hotel-Haartrockner die höchste Qualität solcher Motoren ausgewählt. Durchschnittliche Lebensdauer: etwa 800 Stunden.

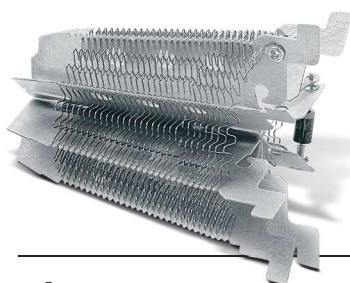

RIPPLE WIRE SECURITY HEATING ELEMENT

VALERA uses exclusively SECURITY ripple wire heating elements. The shape of the electric filament is directly formed on the mica card bearing. The assembling process is fully automatic in order to ensure an excellent stability. This superior type of heating element allows higher quality and safety, more constant distribution of the temperature of the air flow and ensures a longer life if compared with common spiral wire heating elements.

WELLDRAHTHEIZELEMENT SECURITY

VALERA verwendet ausschließlich SECURITY Welldrahtheizelemente. Der Heizdraht ist nicht spiralförmig, sondern wellenförmig geformt. Die gesamte Heizdrahtverarbeitung erfolgt vollkommen automatisch direkt auf dem Mikant-Träger. Dadurch wird höchste Präzision garantiert, was wiederum eine gleichmäßige Verteilung der Temperatur und eine längere Lebensdauer des Heizelementes bedeutet. Höchste Qualität, höchste Sicherheit.

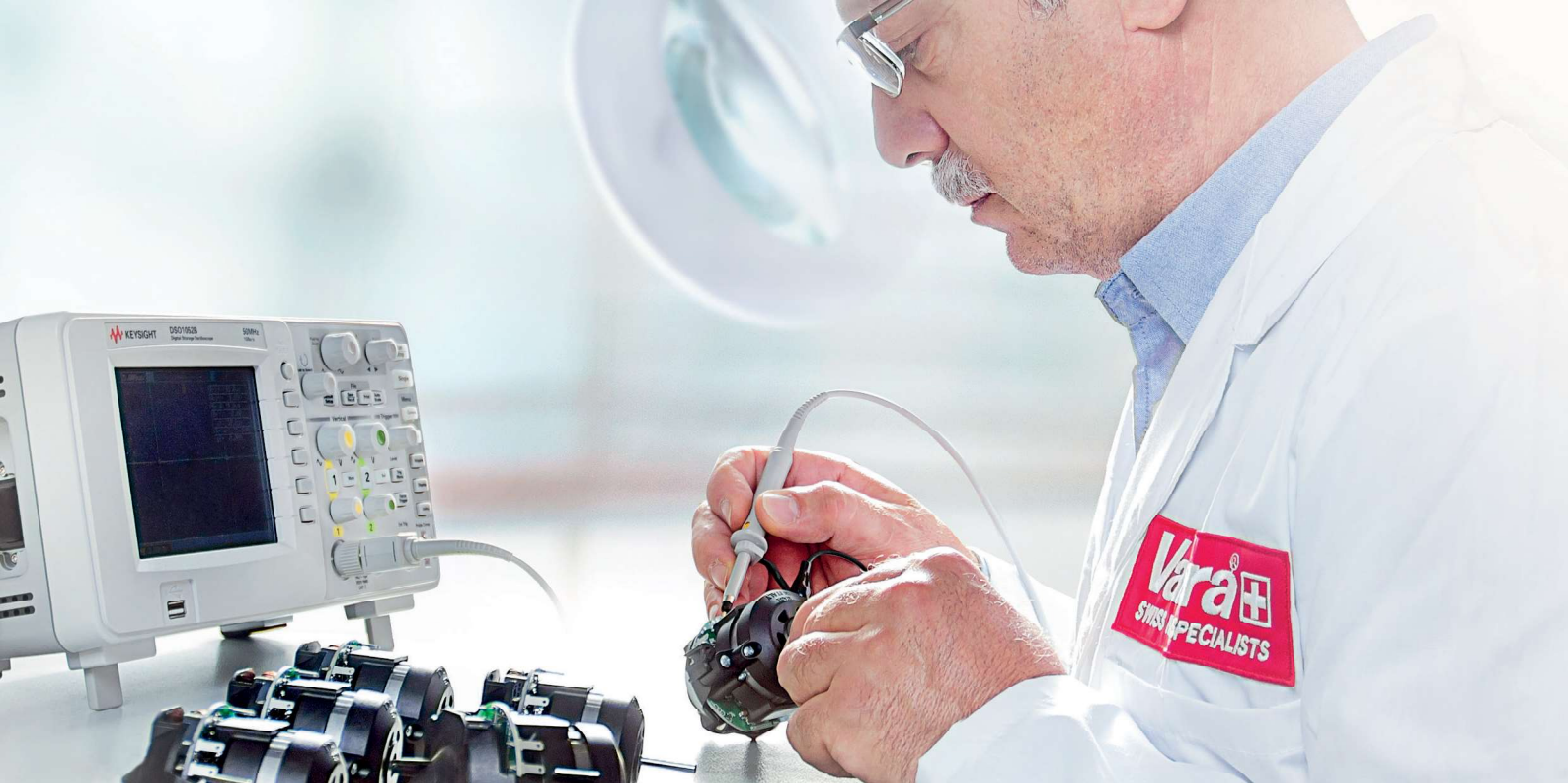

MOTORE ENDURO BRUSHLESS DIGITAL BLDC

Nei motori BLDC brushless, quattro potenti magneti al neodimioferro-boro sostituiscono le spazzole di grafite di carbone usate nei motori convenzionali e soggette a usura per via dell'attrito sul rotore. Questi motori garantiscono una durata fino a 10.000 ore (5 volte in più rispetto ai motori AC), hanno un peso ridotto e non inquinano l'ambiente con emissioni di polvere di carbone.

MOTEUR ENDURO BRUSHLESS DIGITAL BLDC

Dans les moteurs BLDC, quatre aimants de néodyme-fer-bore extrêmement puissants, remplacent les balais au charbon graphite des moteurs traditionnels, soumis à usure par frottement sur le rotor. Ils garantissent une durée maximale de fonctionnement de 10.000 heures (cinq fois plus que les moteurs AC), un poids léger et permettent d'éviter la pollution causée par les émissions de poussière de charbon.

MOTORE A COLLETTORE AC LONG-LIFE

I motori AC (Corrente Alternata) sono motori tradizionalmente usati negli asciugacapelli professionali. Essi producono una grande portata e pressione dell'aria e garantiscono una vita estremamente lunga. Durata media del motore: 2000 ore.

MOTEUR À COLLECTEUR AC LONG-LIFE

Les moteurs AC (Courant Alternatif) sont traditionnellement utilisés dans les sèche-cheveux professionnels. Ils procurent un grand flux et pression de l'air et garantissent une durée de vie extrêmement longue. Durée moyenne du moteur : 2000 heures.

MOTORE DC-PRO LONG-LIFE

I motori ultraleggeri DC-PRO sono una nuova generazione di motori DC (Corrente Continua). Grazie alla esclusiva aerodinamica degli asciugacapelli professionali VALERA, i motori DC-PRO assicurano una elevata portata e pressione dell'aria molto simile a quella prodotta dai più pesanti classici motori AC e quindi adeguata all'uso di bocchette strette professionali. Durata media del motore: 1200 ore.

MOTEUR DC-PRO LONG-LIFE

Les moteurs ultra légers DC-PRO appartiennent à une nouvelle génération de moteurs DC (Courant Continu). Grâce à l'aérodynamisme exclusif des sèche-cheveux professionnels VALERA, les moteurs DC-PRO assurent un flux et pression de l'air similaire à celle des moteurs AC traditionnels, plus lourd et approprié à l'emploi d'embouts professionnels très étroits. Durée moyenne du moteur : 1200 heures.

MOTORE DC COMPATTO

I motori DC sono motori in corrente continua. La loro leggerezza e le dimensioni ridotte consentono un design di asciugacapelli molto compatti. VALERA ha selezionato la più alta qualità di tali motori per i suoi classici asciugacapelli compatti da hotel. Durata media del motore: 800 ore.

MOTEUR DC COMPACT

Les moteurs DC sont des moteurs à "courant continu". Leur poids ultraléger et leur petite taille permettent des designs très compacts de sèche-cheveux. VALERA a sélectionné la plus haute qualité de ces moteurs pour ses sèche-cheveux d'hôtels classiques et compacts. La durée de vie moyenne prévue de ce moteur est d'env. 800 h.

RESISTENZA A ONDA SECURITY

VALERA utilizza esclusivamente resistenze a onda SECURITY. Queste sono riconoscibili dalla caratteristica ondulazione del filamento resistivo e si distinguono dalle resistenze a spirale di basso livello qualitativo. Le resistenze ad onda sono prodotte in automatico, hanno una grande stabilità e garantiscono un migliore controllo della temperatura e dei dispositivi di sicurezza installati oltre che una maggiore durata nel tempo. Massima qualità, massima sicurezza.

ÉLÉMENT CHAUFFANT À ONDE SECURITY

VALERA utilise exclusivement des résistances aux ondes SECURITY. Elles sont facilement reconnaissables à leur filament de résistance ondulé et se distinguent des résistances à spirale de qualité médiocre. Les résistances aux ondes sont produites automatiquement. Elles sont très stables, garantissent un meilleur contrôle de la température et des dispositifs de sécurité installés et ont une durée de vie maximale. La qualité et la sécurité au top.



NEW
ELECTROSTOP
FOR HIGHEST
PROTECTION



VALERA PROTECT
FOR THE HIGHEST SAFETY IN THE BATHROOM
New wall-mounted hairdryers with a residual current device

The ElectroStop residual current device (RCD) in the wall holder minimizes the risk of electrocution from electric shocks caused by any potential leakage current (e.g. the hairdryer accidentally coming into contact with water). ElectroStop is essential in rooms with no residual current device. Moreover, thanks to its rated differential current ≤ 10 mA, ElectroStop is much more sensitive and effective than the commonly installed devices rated ≤ 30 mA.

VALERA PROTECT
FÜR HÖCHSTE SICHERHEIT IM BAD
Die neuen Wandhaartrockner mit Fehlerstrom-Schutzschalter

Der Fehlerstrom-Schutzschalter ElectroStop im Wandhalter minimiert das Risiko eines gesundheitsgefährdenden Stromschlags aufgrund eines Fehlerstroms (z.B. bei versehentlichem Kontakt des Haartrockners mit Wasser). ElectroStop ist fundamental in Räumen ohne Fehlerstrom-Schutzschalter. Darüber hinaus ist ElectroStop dank seines Bemessungsdifferenzstroms ≤ 10 mA wesentlich sensibler und effektiver als die üblicherweise installierten Fehlerstrom-Schutzschalter mit ≤ 30 mA.

VALERA PROTECT
PER LA MASSIMA SICUREZZA IN BAGNO
I nuovi asciugacapelli murali con interruttore differenziale

L'interruttore differenziale ElectroStop presente nel supporto dell'asciugacapelli riduce al minimo il rischio di folgorazione da scossa elettrica per una eventuale corrente di dispersione (p.es. per contatto accidentale dell'asciugacapelli con acqua). ElectroStop è essenziale in ambienti sprovvisti di interruttore differenziale. Inoltre, grazie alla sua corrente differenziale nominale ≤ 10 mA, ElectroStop è molto più sensibile ed efficace rispetto ai dispositivi comunemente installati con una corrente differenziale nominale ≤ 30 mA.

VALERA PROTECT
POUR UN MAXIMUM DE SÉCURITÉ
DANS LA SALLE DE BAIN

Les nouveaux sèche-cheveux mural avec interrupteur différentiel

L'interrupteur différentiel ElectroStop dans le support du sèche-cheveux minimise le risque d'électrocution dû au courant de fuite éventuel (par ex. par contact accidentel du sèche-cheveux avec de l'eau). ElectroStop est essentiel dans les environnements sans interrupteur différentiel. De plus, grâce à son courant différentiel nominal ≤ 10 mA, ElectroStop est beaucoup plus sensible que le courant ≤ 30 mA des interrupteurs différentiels couramment installés.



AUTOMATIC ON/OFF
SAFETY SWITCH

VALERA SECURITY CONCEPTS



HAIRDRYERS EQUIPPED WITH

HAARTROCKNER VERFÜGEN ÜBER

ASCIUGACAPELLI DOTATI DI

SÈCHE-CHEVEUX AVEC



1. Auto-reset switch-off thermostat to prevent overheating
2. Security on/off "Push" button to prevent unguarded operation
3. **Automatic on/off safety switch** to stop operation when hairdryer is inserted in the wall holder
4. **Residual current device in the wall holder (RCD)**



ElectroStop

1. Thermoschalter mit automatischer Rückschaltung zum Schutz vor Überhitzung
2. Ein/Aus-Druckschalter zur Vermeidung unbewachten Betriebs
3. **Ein/Aus-Sicherheitsautomatik zum Abschalten**, wenn der Haartrockner in den Wandhalter eingesetzt wird
4. **Fehlerstrom-Schutzschalter im Wandhalter**

1. Termostato a riarmo automatico per evitare surriscaldamenti
2. Pulsante acceso/spento per prevenire il funzionamento incustodito
3. **Interruttore automatico di sicurezza on/off** per interrompere il funzionamento quando l'asciugacapelli è inserito nel supporto
4. **Interruttore differenziale nel supporto**

1. Thermostat à réarmement automatique pour éviter les surchauffes
2. Bouton poussoir on/off pour éviter le fonctionnement sans surveillance
3. **Interruteur de sécurité automatique on/off** pour arrêter le fonctionnement lorsque le sèche-cheveux est inséré dans le support
4. **Interruteur différentiel dans le support**



1. Auto-reset switch-off thermostat to prevent overheating
2. Security on/off "Push" button to prevent unguarded operation
3. Safety on/off switch of the wall holder to stop operation if needed

1. Thermoschalter mit automatischer Rückschaltung zum Schutz vor Überhitzung
2. Ein/Aus-Druckschalter zur Vermeidung unbewachten Betriebs
3. Ein/Aus-Sicherheitsschalter im Wandhalter zum Abschalten bei Bedarf

1. termostato a riarmo automatico per evitare surriscaldamenti
2. pulsante acceso/spento per prevenire il funzionamento incustodito
3. Interruttore acceso/spento nel supporto per spegnere l'apparecchio se necessario

1. Thermostat à réarmement automatique pour éviter les surchauffes
2. Bouton poussoir on/off pour éviter le fonctionnement sans surveillance
3. Interruteur de sécurité on/off dans le support pour éteindre si nécessaire



1. Auto-reset switch-off thermostat to prevent overheating
2. Security thermal cutoff in case of accidental overheating

1. Thermoschalter mit automatischer Rückschaltung zum Schutz vor Überhitzung
2. Thermosicherung im Falle versehentlichen Überhitzens

1. Termostato a riarmo automatico per evitare surriscaldamenti
2. Termofusibile di sicurezza in caso di surriscaldamento accidentale

1. Thermostat à réarmement automatique pour éviter les surchauffes
2. Fusible thermique de sécurité en cas de surchauffe accidentelle



1. Auto-reset switch-off thermostat to prevent overheating
2. Security on/off "Push" button to prevent unguarded operation

1. Thermoschalter mit automatischer Rückschaltung zum Schutz vor Überhitzung
2. Ein/Aus-Druckschalter zur Vermeidung unbewachten Betriebs

1. Termostato a riarmo automatico per evitare surriscaldamenti
2. Pulsante acceso/spento per prevenire il funzionamento incustodito

1. Thermostat à réarmement automatique pour éviter les surchauffes
2. Bouton poussoir on/off pour éviter le fonctionnement sans surveillance



HAIRDRYERS FOR **HEAVY DUTY** USE

For public areas with **high frequency of users**,
such as swimming pools, gyms, wellness/fitness clubs, spas, etc.

Für öffentliche Anlagen mit **hoher Nutzungsfrequenz**,
wie Schwimm- und Sporthallen, Wellness- und Fitness-Clubs, Spas usw.

Per impianti pubblici con **alta frequenza di utenti**,
come piscine, palestre, wellness/fitness clubs, spa, ecc.

Pour structures publiques avec **grande fréquence d'utilisation**,
comme piscines, gymnases, clubs de wellness/fitness, spa, etc.



HOTELLO BLDC



**EXTREMELY
DURABLE**
ULTRA-POWER
1500W





BRUSHLESS

ENDURO
BLDC MOTOR
10.000 h
HEAVY DUTY

SPLASH PROOF

**Wall-mounted hairdryer with hose**

- Super compact (147 x 238 mm) – fits everywhere
- Powerful airflow thanks to a re-designed aeration module
- Durable “Heavy Duty” ENDURO Brushless BLDC motor
- Automatic switching on when removing the handgrip from holder
- 8 mins automatic safety timer
- “Cool touch” swivel handgrip
- Extensible hose (up to m 1,20)
- Easy wall-mounting without opening
- 2 possibilities of electrical wiring: direct connection to electrical mains (hardwire), connection with plug (softwire)
- Fixation screws and screw anchors included

Wandhaartrockner mit Schlauch

- Super kompakt (147 x 238 mm) – passt überall
- Kraftvoller Luftstrom dank neu konzipierter Lüftungsgruppe
- Langlebiger “Heavy Duty”- Motor ENDURO Brushless BLDC
- Automatische Einschaltung nach Handgriff-Abnahme
- 8 Min. Sicherheits-Zeitschalter
- Cool-touch-Handgriff drehbar
- Flexibler Schlauch 1,20 m
- Praktische Wandmontage ohne das Gerät öffnen zu müssen
- 2 Anschlussmöglichkeiten: Elektrischer Festanschluss, Direkter Steckeranschluss
- Einschl. Schrauben und Dübel zur Wandbefestigung

Asciugacapelli murale a tubo

- Super compatto (147 x 238 mm) – sta dappertutto
- Potente flusso d'aria grazie al gruppo ventilazione di nuova concezione
- Motore durevole “Heavy Duty” ENDURO Brushless BLDC
- Accensione automatica a sganciamento bocchetta
- Timer di sicurezza 8 min.
- Bocchetta cool-touch girevole
- Tubo flessibile estensibile fino a m 1,20
- Pratico montaggio a muro senza necessità di aprire l'apparecchio
- 2 possibilità di allacciamento a rete: diretto a cavo di rete che esce dal muro, alla presa tramite cavo con spina
- Completo di tasselli + viti per il fissaggio a muro

Sèche-cheveux à montage mural avec tuyau

- Super compact (147 x 238 mm) – s'adapte partout
- Flux d'air puissant grâce au groupe de ventilation de nouvelle conception
- Durable moteur “heavy duty” ENDURO Brushless BLDC
- Allumage automatique à la prise en main du flexible
- Temporisateur de sécurité 8 min
- Embout « cool touch » tournant
- Tuyau souple extensible jusqu'à 1,20 m
- Montage au mur pratique sans ouverture de l'appareil
- 2 possibilités de raccordement au réseau électrique: raccord direct par câble d'alimentation à boîtier mural, raccord par câble avec fiche à prise électrique
- Jeu complet de chevilles + vis pour fixation au mur

COLOURS: WHITE 

SWISS MADE

The Technology of DURABILITY

Brushless frictionless motor with 4 strong rare earth magnets (NdFeB) for up to 10,000 hours life without carbon dust emissions. Integrated electronic control, extra light, extremely powerful.

Die Technologie der Langlebigkeit

Bürstenloser reibungsfreier Motor mit 4 starken Seltenerdmetallen (Nd-FeB) für bis zu 10.000 Std. Lebensdauer ohne Kohlenstaub-Emission. Integrierte elektronische Steuerung, extra leicht, extrem leistungsfähig.

La tecnologia della longevità

Motore brushless senza contatti striscianti con 4 potenti magneti a terra rara (NdFeB) per una durata di vita fino a 10.000 ore senza emissione di polvere di carbone. Controllo elettronico integrato, superleggero, estrema potenza.

La technologie de la longévité

Moteur brushless et sans frictions, avec quatre aimants (NdFeB) puissants pour une durée de vie jusqu'à 10.000 heures sans émissions de poussière de charbon. Commande électronique intégrée, très léger, extrêmement performant.

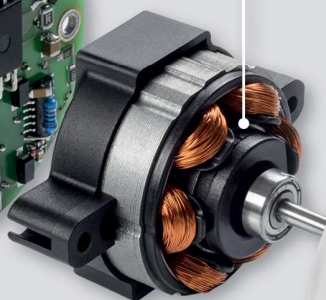
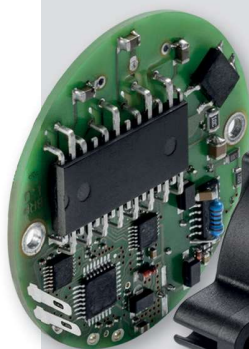
 BRUSHLESS
ENDURO
 BLDC MOTOR
 10.000 h
 HEAVY DUTY

A photograph of a modern gym interior. The room features a light-colored wooden floor, a white ceiling with recessed lighting, and large windows with blinds. In the foreground, several treadmills and exercise machines are visible, arranged in a row. The overall atmosphere is clean and bright.

HAIRDRYERS FOR **MEDIUM DUTY** USE

For small public places with **low frequency of users**,
such as swimming pools, gyms, wellness/fitness clubs, spas, etc.

Für kleinere öffentliche Einrichtungen mit **niedriger Nutzungsfrequenz**,
wie Schwimm- und Sporthallen, Wellness- und Fitness-Clubs, Spas usw.

Per piccoli impianti pubblici con **bassa frequenza di utenti**,
come piscine, palestre, wellness/fitness clubs, spa, ecc.

Pour petites installations publiques avec **basse fréquence d'utilisation**,
comme piscines, gymnases, clubs de wellness/fitness, spa, etc.



HAIRDRYERS for
MEDIUM DUTY USE

HOTELLO SUPER AC



SUPER POWER
1400W

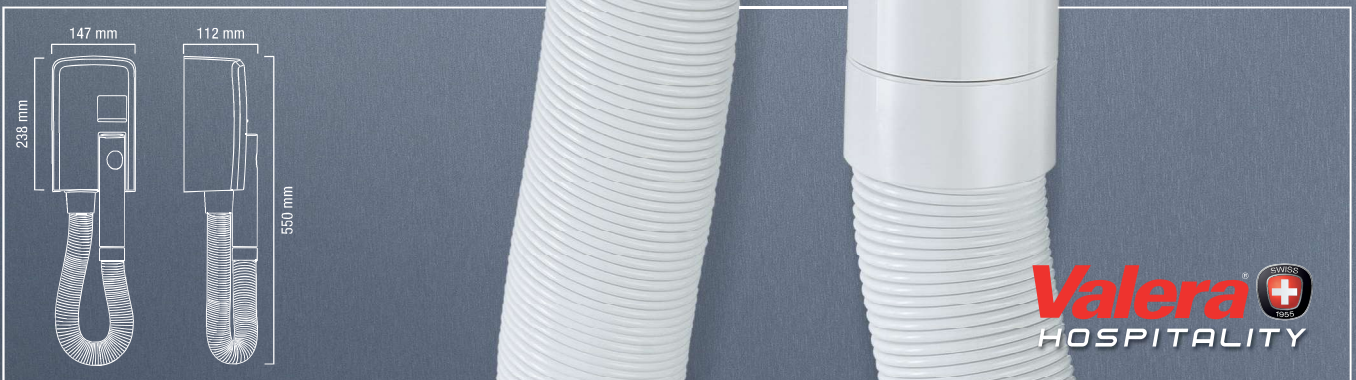



AC MOTOR

+1500 h
EXTRA LONG LIFEAUTOMATIC
TIMER

IP34

SPLASH PROOF

SUPER
EASY
INSTALLATIONCOOL
TOUCHSUPER
SAFETY**Wall-mounted hairdryer with hose**

- Super compact (147 x 238 mm) – fits everywhere
- Powerful airflow thanks to a re-designed aeration module
- EXTRA LONG-LIFE AC Universal Motor
- Automatic switching on when removing the handgrip from holder
- 8 mins automatic safety timer
- "Cool touch" swivel handgrip
- Extensible hose (up to m 1,20)
- Easy wall-mounting without opening
- 2 possibilities of electrical wiring:
 - direct connection to electrical mains (hardwire), connection with plug (softwire)
- Fixation screws and screw anchors included

Wandhaartrockner mit Schlauch

- Super kompakt (147 x 238 mm) – passt überall
- Kraftvoller Luftstrom dank neu konzipierter Lüftungsgruppe
- AC-Kollektormotor EXTRA LONG-LIFE
- Automatische Einschaltung nach Handgriff-Abnahme
- 8 Min. Sicherheits-Zeitschalter
- Cool-touch-Handgriff drehbar
- Flexibler Schlauch 1,20 m
- Praktische Wandmontage ohne das Gerät öffnen zu müssen
- 2 Anschlussmöglichkeiten:
 - Elektrischer Festanschluss, Direkter Steckeranschluss
- Einschl. Schrauben und Dübel zur Wandbefestigung

COLOURS: WHITE **Asciugacapelli murale a tubo**

- Super compatto (147 x 238 mm) – sta dappertutto
- Potente flusso d'aria grazie al gruppo ventilazione di nuova concezione
- Motore a collettore AC EXTRA LONG-LIFE
- Accensione automatica a sganciamento bocchetta
- Timer di sicurezza 8 min
- Bocchetta cool-touch girevole
- Tubo flessibile estensibile fino a m 1,20
- Pratico montaggio a muro senza necessità di aprire l'apparecchio
- 2 possibilità di allacciamento a rete:
 - diretto a cavo di rete che esce dal muro, alla presa tramite cavo con spina
- Completo di tasselli + viti per il fissaggio a muro

Sèche-cheveux à montage mural avec tuyau

- Super compact (147 x 238 mm) – s'adapte partout
- Flux d'air puissant grâce au groupe de ventilation de nouvelle conception
- Moteur à collecteur AC EXTRA LONG-LIFE
- Allumage automatique à la prise en main du flexible
- Temporisateur de sécurité 8 min
- Embout « cool touch » tournant
- Tuyau souple extensible jusqu'à 1,20 m
- Montage au mur pratique sans ouverture de l'appareil
- 2 possibilités de raccordement au réseau électrique:
 - raccord direct par câble d'alimentation à boîtier mural, raccord par câble avec fiche à prise électrique
- Jeu complet de chevilles + vis pour fixation au mur



SWISS MADE

110-120 V
220-240 VSECURITY
SHAVER
SOCKET

AC MOTOR

+1500 h
EXTRA LONG LIFEAUTOMATIC
TIMER

IP34

SPLASH PROOF

SUPER
EASY
INSTALLATIONCOOL
TOUCHSUPER
SAFETY**HOTELLO SUPER AC SHAVER - 1400W****Wall-mounted hairdryer with hose**

- Super compact (147 x 238 mm) – fits everywhere
- Powerful airflow thanks to a re-designed aeration module
- EXTRA LONG-LIFE AC Universal Motor
- Automatic switching on when removing the handgrip from holder
- 8 mins automatic safety timer
- "Cool touch" swivel handgrip
- Extensible hose (up to m 1,20)
- Shaver socket 110-120V and 220-240V
- Safety isolating transformer
- Easy wall-mounting without opening
- 2 possibilities of electrical wiring:
 - direct connection to electrical mains (hardwire), connection with plug (softwire)
- Fixation screws and screw anchors included

Wandhaartrockner mit Schlauch

- Super kompakt (147 x 238 mm) – passt überall
- Kraftvoller Luftstrom dank neu konzipierter Lüftungsgruppe
- AC-Kollektormotor EXTRA LONG-LIFE
- Automatische Einschaltung nach Handgriff-Abnahme
- 8 Min. Sicherheits-Zeitschalter
- Cool-touch-Handgriff drehbar
- Flexibler Schlauch 1,20 m
- Rasiersteckdose 110-120V und 220-240 V
- Sicherheits-Trenntransformator
- Praktische Wandmontage ohne das Gerät öffnen zu müssen
- 2 Anschlussmöglichkeiten:
 - Elektrischer Festanschluss, Direkter Steckeranschluss
- Einschl. Schrauben und Dübel zur Wandbefestigung

COLOURS: WHITE **Asciugacapelli murale a tubo**

- Super compatto (147 x 238 mm) – sta dappertutto
- Potente flusso d'aria grazie al gruppo ventilazione di nuova concezione
- Motore a collettore AC EXTRA LONG-LIFE
- Accensione automatica a sganciamento bocchetta
- Timer di sicurezza 8 min
- Bocchetta cool-touch girevole
- Tubo flessibile estensibile fino a m 1,20
- Presa rasoio 110-120V e 220-240V
- Trasformatore d'isolamento di sicurezza
- Pratico montaggio a muro senza necessità di aprire l'apparecchio
- 2 possibilità di allacciamento a rete:
 - diretto a cavo di rete che esce dal muro, alla presa tramite cavo con spina
- Completo di tasselli + viti per il fissaggio a muro

Sèche-cheveux à montage mural avec tuyau

- Super compact (147 x 238 mm) – s'adapte partout
- Flux d'air puissant grâce au groupe de ventilation de nouvelle conception
- Moteur à collecteur AC EXTRA LONG-LIFE
- Allumage automatique à la prise en main du flexible
- Temporisateur de sécurité 8 min
- Embout « cool touch » tournant
- Tuyau souple extensible jusqu'à 1,20 m
- Prise rasoir 110-120V et 220-240V
- Transformateur de sécurité
- Montage au mur pratique sans ouverture de l'appareil
- 2 possibilités de raccordement au réseau électrique:
 - raccord direct par câble d'alimentation à boîtier mural, raccord par câble avec fiche à prise électrique
- Jeu complet de chevilles + vis pour fixation au mur



SWISS MADE

SILENT JET PROTECT

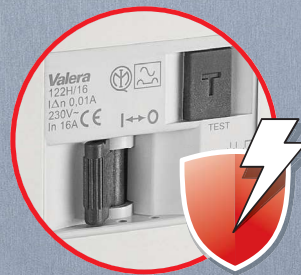

ElectroStop

PROFESSIONAL POWER
2000 W



Valera
HOSPITALITY



SILENT JET PROTECT 2000 SHAVER-2000W MOD. 586.10/044.06



New



Hairdryer

- LONG-LIFE AC Universal Motor
- 6 air flow/temperature settings
- Removable metallic filter
- Concentrator nozzle
- On/Off push button

Wall holder

- ELECTROSTOP - Residual current device $\leq 10\text{mA}$
- Shaver socket 110-120V and 220-240V
- Safety isolating transformer
- Automatic On/Off safety switch

Haartrockner

- Kollektormotor AC LONG-LIFE
- 6 Temperatur/Luftstrom-Schaltkombinationen
- Abnehmbarer Metallfilter
- Ondulierdüse
- Ein/Aus-Druckschalter

Wandhalter

- ELECTROSTOP - Fehlerstrom-Schutzschalter $\leq 10\text{mA}$
- Rasiersteckdose 110-120V und 220-240V
- Sicherheits-Trenntransformator
- Automatischer Ein/Aus-Sicherheitsschalter

Asciugacapelli

- Motore a collettore AC LONG-LIFE
- 6 combinazioni di temperatura/flusso dell'aria
- Filtro metallico removibile
- Bocchetta
- Pulsante acceso/spento

Supporto da parete

- ELECTROSTOP - Interruttore differenziale $\leq 10\text{mA}$
- Presa rasoio 110-120V e 220-240V
- Trasformatore d'isolamento di sicurezza
- Interruttore automatico di sicurezza acceso/spento

Sèche-cheveux

- Moteur à collecteur AC LONG-LIFE
- 6 combinaisons de température/ventilation
- Filtre métallique amovible
- Concentrateur d'air
- Bouton poussoir on/off

Support mural

- ELECTROSTOP - Interrupteur différentiel $\leq 10\text{mA}$
- Prise rasoir 110-120V et 220-240V
- Transformateur de sécurité
- Interrupteur de sécurité on/off automatique

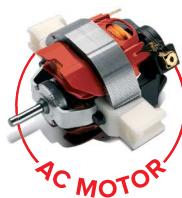

COLOURS: WHITE



SWISS MADE

ElectroStop

HAIRDRYERS for
MEDIUM DUTY USE

SILENT JET PROTECT 2000 - 2000W MOD. 586.10/044.04



New



Hairdryer

- LONG-LIFE AC Universal Motor
- 6 air flow/temperature settings
- Removable metallic filter
- Concentrator nozzle
- On/Off push button

Wall holder

- ELECTROSTOP - Residual current device $\leq 10\text{mA}$
- Automatic On/Off safety switch

Haartrockner

- Kollektormotor AC LONG-LIFE
- 6 Temperatur/Luftstrom-Schaltkombinationen
- Abnehmbarer Metallfilter
- Ondulierdüse
- Ein/Aus-Druckschalter

Wandhalter

- ELECTROSTOP - Fehlerstrom-Schutzschalter $\leq 10\text{mA}$
- Automatischer Ein/Aus-Sicherheitsschalter

Asciugacapelli

- Motore a collettore AC LONG-LIFE
- 6 combinazioni di temperatura/flusso dell'aria
- Filtro metallico removibile
- Bocchetta
- Pulsante acceso/spento

Supporto da parete

- ELECTROSTOP - Interruttore differenziale $\leq 10\text{mA}$
- Interruttore automatico di sicurezza acceso/spento

Sèche-cheveux

- Moteur à collecteur AC LONG-LIFE
- 6 combinaisons de température/ventilation
- Filtre métallique amovible
- Concentrateur d'air
- Bouton poussoir on/off

Support mural

- ELECTROSTOP - Interrupteur différentiel $\leq 10\text{mA}$
- Interrupteur de sécurité on/off automatique

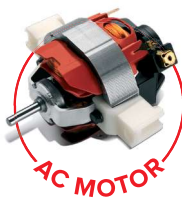

COLOURS: WHITE



SWISS MADE

ElectroStop

SWISS METAL MASTER



PROFESSIONAL POWER
2000 W

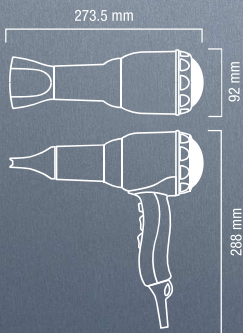

Valera 
HOSPITALITY



ON/OFF
PUSH
BUTTON
SECURITY



SWISS METAL MASTER PUSH - 2000W

MOD. 584.02/IP

Professional steel hairdryer

- Metal body in chrome plated premium steel
- LONG-LIFE AC Universal Motor
- Ions generator
- 6 air flow/temperature combinations
- On/Off push button
- Ultra-narrow concentrator nozzle
- Removable metallic filter
- Spiral cable

Professioneller Metall-Haartrockner

- Metallgehäuse aus verchromtem Premium-Stahl
- LONG-LIFE AC Kollektormotor
- Ionen-Generator
- 6 Temperatur/Luftstrom-Schaltkombinationen
- Ein/Aus-Druckschalter
- Extra schmale Ondulierdüse
- Abnehmbarer Metallfilter
- Spiralkabel

Asciugacapelli professionale in metallo

- Corpo in acciaio cromato Premium
- Motore a collettore AC LONG-LIFE
- Generatore di ioni
- 6 combinazioni di temperatura/flusso dell'aria
- Pulsante acceso/spento
- Bocchetta ultra stretta
- Filtro metallico removibile
- Cordone spiralato

Sèche-cheveux professionnel en métal

- Corps en acier chromé Premium
- Moteur à collecteur AC LONG-LIFE
- Ionisateur
- 6 combinaisons de température/ventilation
- Bouton poussoir on/off
- Embout concentrateur ultra-fin
- Filtre métallique amovible
- Cordon spiralé

COLOURS: SILVER 

Mod. dép.



SWISS  MADE

SWISS SILENT JET 8500 PUSH -2000W

MOD. SXJ 8500 P



ULTRA SILENT



SMART AIRFLOW TECHNOLOGY

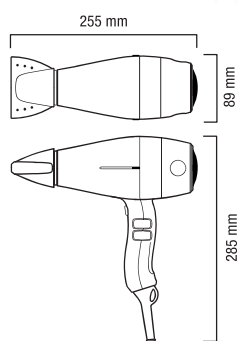

Ultra-silent professional hairdryer

- LONG-LIFE AC Universal Motor
- 6 air flow/temperature settings
- On/Off push button
- Removable metallic filter
- TOUCH ME cool nozzle (7,5 cm)
- Spiral cable

Ultraleiser professioneller Haartrockner

- Kollektormotor AC LONG-LIFE
- 6 Temperatur/Luftstrom-Schaltkombinationen
- Ein/Aus-Druckschalter
- Abnehmbarer Metallfilter
- Kühle Düse TOUCH ME (7,5 cm)
- Spiralkabel

Asciugacapelli professionale ultra silenzioso

- Motore a collettore AC LONG-LIFE
- 6 combinazioni di temperatura/flusso dell'aria
- Pulsante acceso/spento
- Filtro metallico removibile
- Bocchetta fredda TOUCH ME (7,5 cm)
- Cordone spiralato

Sèche-cheveux professionnel ultra-silencieux

- Moteur à collecteur AC LONG-LIFE
- 6 combinaisons de température/ventilation
- Bouton poussoir on/off
- Filtre métallique amovible
- Embout froid TOUCH ME (7,5 cm)
- Cordon spiralé

COLOURS: BLACK ■

Mod. dép.



SWISS MADE

HAIRDRYERS for
MEDIUM DUTY USE



ULTRA SILENT



SMART AIRFLOW TECHNOLOGY

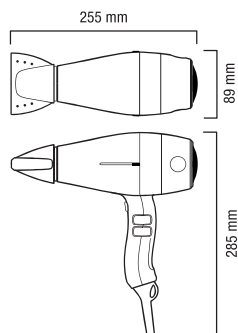

SWISS SILENT JET 8500 IONIC TF -2000W

MOD. SXJ 8500 RC TF

Ultra-silent professional hairdryer

- LONG-LIFE AC Universal Motor
- Security thermal cutoff
- Ions generator
- 6 air flow/temperature settings
- Cold air button
- Removable metallic filter
- 2 professional ultra-slim concentrator nozzles: TOUCH ME and standard
- SuperFlex cable 3 m with ROTOCORD

Ultraleiser professioneller Haartrockner

- Kollektormotor AC LONG-LIFE
- Thermosicherung
- Ionen-Generator
- 6 Temperatur/Luftstrom-Schaltkombinationen
- Kaltlufttaste
- Abnehmbarer Metallfilter
- 2 professionelle extra schmale Ondulierzüsen: TOUCH ME und Standard
- Super-Flex-Kabel 3 m mit ROTOCORD

Asciugacapelli professionale ultra silenzioso

- Motore a collettore AC LONG-LIFE
- Termofusibile di sicurezza
- Generatore di ioni
- 6 combinazioni di temperatura/flusso dell'aria
- Tasto aria fredda
- Filtro metallico removibile
- 2 bocchette professionali ultrastrrette: TOUCH ME e standard
- Cordone SuperFlex 3 m con ROTOCORD

Sèche-cheveux professionnel ultra-silencieux

- Moteur à collecteur AC LONG-LIFE
- Fusible thermique de sécurité
- Ionisateur
- 6 combinaisons de température/ventilation
- Bouton à air froid
- Filtre métallique amovible
- 2 embouts concentrateurs professionnelles ultra-fins: TOUCH ME et standard
- Câble SuperFlex 3 m avec ROTOCORD

COLOURS: BLACK ■

Mod. dép.



SWISS MADE



HAIRDRYERS FOR **HOTEL ROOMS**

For **non-public areas**, such as hotel bedrooms/bathrooms, guest-houses, ships cabins and private homes.

Für **nichtöffentliche Bereiche** wie Gästezimmer oder -bäder von Hotels, Pensionen, Schiffskabinen sowie private Wohnungen.

Per **aree non pubbliche**, come camere/bagni privati di alberghi, pensioni, cabine di navi e abitazioni private.

Pour **zones non publiques**: chambres à coucher/salles de bains privées d'hôtels, pensions, cabines d'embarcations et habitations privées.



HAIRDRYERS for
HOTEL ROOMS

HOTELLO



Valera 
HOSPITALITY



HOTELLO - 1200W

MOD. 832.01/T



SPLASH PROOF



Wall-mounted hairdryer with hose

- Super compact (147 x 238 mm) – fits everywhere
- Powerful airflow thanks to a re-designed aeration module
- Automatic switching on when removing the handgrip from holder
- 8 mins automatic safety timer
- "Cool touch" swivel handgrip
- Extensible hose (up to m 1,20)
- Easy wall-mounting without opening
- 2 possibilities of electrical wiring:
 - direct connection to electrical mains (hardwire),
 - connection with plug (softwire).
- Fixation screws and screw anchors included

Wandhaartrockner mit Schlauch

- Super kompakt (147 x 238 mm) – passt überall
- Kraftvoller Luftstrom dank neu konzipierter Lüftungsgruppe
- Automatische Einschaltung nach Handgriff-Abnahme
- 8 Min. Sicherheits-Zeitschalter
- Cool-touch-Handgriff drehbar
- Flexibler Schlauch 1,20 m
- Praktische Wandmontage ohne das Gerät öffnen zu müssen
- 2 Anschlussmöglichkeiten:
 - Elektrischer Festanschluss,
 - Direkter Steckeranschluss
- Einschl. Schrauben und Dübel zur Wandbefestigung

Asciugacapelli murale a tubo

- Super compatto (147 x 238 mm) – sta dappertutto
- Potente flusso d'aria grazie al gruppo ventilazione di nuova concezione
- Accensione automatica a sganciamento bocchetta
- Timer di sicurezza 8 min
- Bocchetta cool-touch girevole
- Tubo flessibile estensibile fino a m 1,20
- Pratico montaggio a muro senza necessità di aprire l'apparecchio
- 2 possibilità di allacciamento a rete:
 - diretto a cavo di rete che esce dal muro,
 - alla presa tramite cavo con spina
- Completo di tasselli + viti per il fissaggio a muro

Sèche-cheveux à montage mural avec tuyau

- Super compact (147 x 238 mm) – s'adapte partout
- Flux d'air puissant grâce au groupe de ventilation de nouvelle conception
- Allumage automatique à la prise en main du flexible
- Temporisateur de sécurité 8 min
- Embout « cool touch » tournant
- Tuyau souple extensible jusqu'à 1,20 m
- Montage au mur pratique sans ouverture de l'appareil
- 2 possibilités de raccordement au réseau électrique:
 - raccord direct par câble d'alimentation à boîtier mural,
 - raccord par câble avec fiche à prise électrique
- Jeu complet de chevilles + vis pour fixation au mur

COLOURS: WHITE SILVER



SWISS MADE



HOTELLO SHAVER - 1200W

MOD. 832.01/RT



SPLASH PROOF



Wall-mounted hairdryer with hose

- Super compact (147 x 238 mm) – fits everywhere
- Powerful airflow thanks to a re-designed aeration module
- Automatic switching on when removing the handgrip from holder
- 8 mins automatic safety timer
- "Cool touch" swivel handgrip
- Extensible hose (up to m 1,20)
- Shaver socket 110-120V and 220-240V
- Safety isolating transformer
- Easy wall-mounting without opening
- 2 possibilities of electrical wiring:
 - direct connection to electrical mains (hardwire),
 - connection with plug (softwire)
- Fixation screws and screw anchors included

Wandhaartrockner mit Schlauch

- Super kompakt (147 x 238 mm) – passt überall
- Kraftvoller Luftstrom dank neu konzipierter Lüftungsgruppe
- Automatische Einschaltung nach Handgriff-Abnahme
- 8 Min. Sicherheits-Zeitschalter
- Cool-touch-Handgriff drehbar
- Flexibler Schlauch 1,20 m
- Rasiersteckdose 110-120V und 220-240 V
- Sicherheits-Trenntransformator
- Praktische Wandmontage ohne das Gerät öffnen zu müssen
- 2 Anschlussmöglichkeiten:
 - Elektrischer Festanschluss,
 - Direkter Steckeranschluss
- Einschl. Schrauben und Dübel zur Wandbefestigung

Asciugacapelli murale a tubo

- Super compatto (147 x 238 mm) – sta dappertutto
- Potente flusso d'aria grazie al gruppo ventilazione di nuova concezione
- Accensione automatica a sganciamento bocchetta
- Timer di sicurezza 8 min
- Bocchetta cool-touch girevole
- Tubo flessibile estensibile fino a m 1,20
- Presa rasoio 110-120V e 220-240V
- Trasformatore d'isolamento di sicurezza
- Pratico montaggio a muro senza necessità di aprire l'apparecchio
- 2 possibilità di allacciamento a rete:
 - diretto a cavo di rete che esce dal muro,
 - alla presa tramite cavo con spina
- Completo di tasselli + viti per il fissaggio a muro

Sèche-cheveux à montage mural avec tuyau

- Super compact (147 x 238 mm) – s'adapte partout
- Flux d'air puissant grâce au groupe de ventilation de nouvelle conception
- Allumage automatique à la prise en main du flexible
- Temporisateur de sécurité 8 min
- Embout « cool touch » tournant
- Tuyau souple extensible jusqu'à 1,20 m
- Prise rasoir 110-120V et 220-240V
- Transformateur de sécurité
- Montage au mur pratique sans ouverture de l'appareil
- 2 possibilités de raccordement au réseau électrique:
 - raccord direct par câble d'alimentation à boîtier mural,
 - raccord par câble avec fiche à prise électrique
- Jeu complet de chevilles + vis pour fixation au mur

COLOURS: WHITE



SWISS MADE

SILENT JET PROTECT

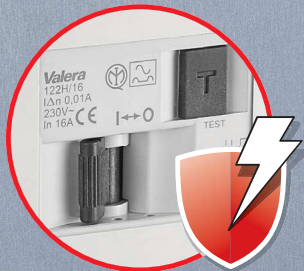

ElectroStop

PROFESSIONAL CARE

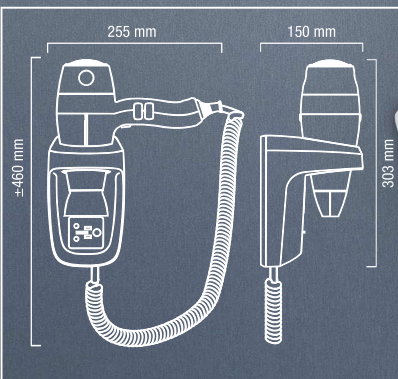

Valera 
HOSPITALITY

SILENT JET PROTECT 1200 SHAVER - 1200W MOD. 586.11/044.06



New



ULTRA SILENT



SMART AIRFLOW TECHNOLOGY



ElectroStop

Hairdryer

- LONG-LIFE DC-Pro Motor
- 6 air flow/temperature settings
- Removable metallic filter
- Concentrator nozzle
- On/Off push button

Wall holder

- ELECTROSTOP - Residual current device $\leq 10\text{mA}$
- Shaver socket 110-120V and 220-240V
- Safety isolating transformer
- Automatic On/Off safety switch

Haartrockner

- Motor DC-Pro LONG-LIFE
- 6 Temperatur/Luftstrom-Schaltkombinationen
- Abnehmbarer Metallfilter
- Ondulierdüse
- Ein/Aus-Druckschalter

Wandhalter

- ELECTROSTOP - Fehlerstrom-Schutzschalter $\leq 10\text{mA}$
- Rasiersteckdose 110-120V und 220-240V
- Sicherheits-Trenntransformator
- Automatischer Ein/Aus-Sicherheitsschalter

Asciugacapelli

- Motore DC-Pro LONG-LIFE
- 6 combinazioni di temperatura/flusso dell'aria
- Filtro metallico removibile
- Bocchetta
- Pulsante acceso/spento

Supporto da parete

- ELECTROSTOP - Interruttore differenziale $\leq 10\text{mA}$
- Presa rasoio 110-120V e 220-240V
- Trasformatore d'isolamento di sicurezza
- Interruttore automatico di sicurezza acceso/spento

Sèche-cheveux

- Moteur DC-Pro LONG-LIFE
- 6 combinaisons de température/ventilation
- Filtre métallique amovible
- Concentrateur d'air
- Bouton poussoir on/off

Support mural

- ELECTROSTOP - Interrupteur différentiel $\leq 10\text{mA}$
- Prise rasoir 110-120V et 220-240V
- Transformateur de sécurité
- Interrupteur de sécurité on/off automatique

COLOURS: WHITE



SWISS MADE

HAIRDRYERS for
HOTEL ROOMS

SILENT JET PROTECT 1200 - 1200W

MOD. 586.11/044.04



New



ULTRA SILENT



SMART AIRFLOW TECHNOLOGY



ElectroStop

Hairdryer

- LONG-LIFE DC-Pro Motor
- 6 air flow/temperature settings
- Removable metallic filter
- Concentrator nozzle
- On/Off push button

Wall holder

- ELECTROSTOP - Residual current device $\leq 10\text{mA}$
- Automatic On/Off safety switch

Haartrockner

- Motor DC-Pro LONG-LIFE
- 6 Temperatur/Luftstrom-Schaltkombinationen
- Abnehmbarer Metallfilter
- Ondulierdüse
- Ein/Aus-Druckschalter

Wandhalter

- ELECTROSTOP - Fehlerstrom-Schutzschalter $\leq 10\text{mA}$
- Automatischer Ein/Aus-Sicherheitsschalter

Asciugacapelli

- Motore DC-Pro LONG-LIFE
- 6 combinazioni di temperatura/flusso dell'aria
- Filtro metallico removibile
- Bocchetta
- Pulsante acceso/spento

Supporto da parete

- ELECTROSTOP - Interruttore differenziale $\leq 10\text{mA}$
- Interruttore automatico di sicurezza acceso/spento

Sèche-cheveux

- Moteur DC-Pro LONG-LIFE
- 6 combinaisons de température/ventilation
- Filtre métallique amovible
- Concentrateur d'air
- Bouton poussoir on/off

Support mural

- ELECTROSTOP - Interrupteur différentiel $\leq 10\text{mA}$
- Interrupteur de sécurité on/off automatique

COLOURS: WHITE



SWISS MADE

EXCEL PROTECT



Valera 

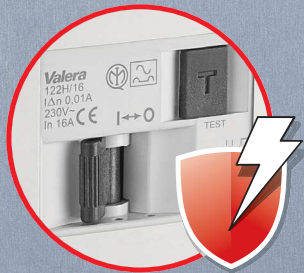

Valera
122H16
1AN 0.01A
230V~
In 16A



ElectroStop

EXCELLENCE 1600W

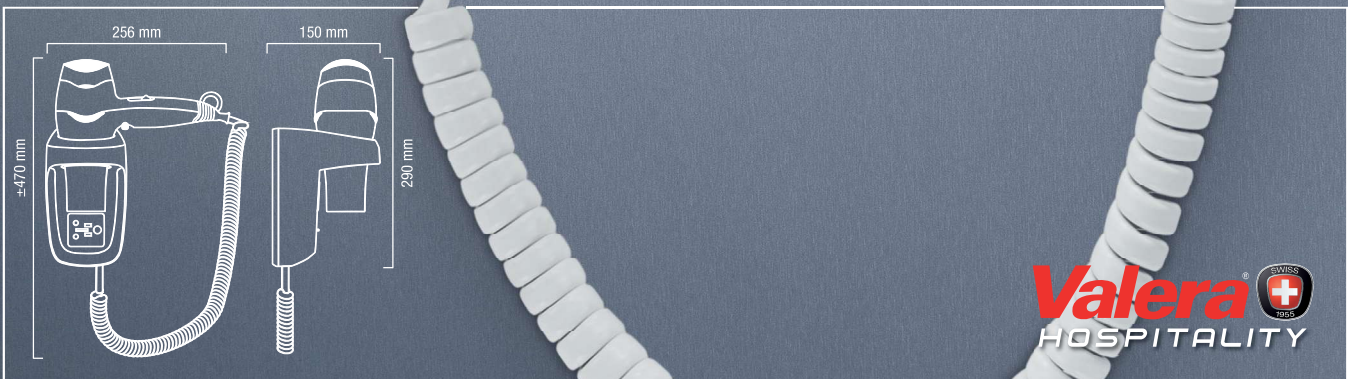

Valera 
HOSPITALITY

EXCEL PROTECT 1600 SHAVER - 1600W

MOD. 561.17/044.06



New

ON/OFF
PUSH
BUTTON
SECURITY

110-120 V
220-240 V

SECURITY
SHAVER
SOCKET

4X
SECURITY

Hairdryer

- Air flow control switch: 2 settings
- Air temperature control switch: 3 settings
- 6 air flow/ temperature combinations
- COOL air setting
- Removable filter
- On/Off push button

Wall holder

- ELECTROSTOP - Residual current device $\leq 10\text{mA}$
- Shaver socket 110-120V and 220-240V
- Safety isolating transformer
- Automatic On/Off safety switch

Haartrockner

- Luftstrom-Einstellung: 2-stufige Schiebetaste
- Lufttemperatur-Einstellung: 3-stufige Schiebetaste
- 6 Schaltkombinationen
- Abkühlstufe COOL
- Abnehmbarer Filter
- Ein/Aus-Druckschalter

Wandhalter

- ELECTROSTOP - Fehlerstrom-Schutzschalter $\leq 10\text{mA}$
- Rasiersteckdose 110-120V und 220-240V
- Sicherheits-Trenntransformator
- Automatischer Ein/Aus-Sicherheitsschalter

Asciugacapelli

- Tasto di regolazione del flusso d'aria: 2 posizioni
- Tasto di regolazione temperatura d'aria: 3 posizioni
- 6 combinazioni di temperatura/flusso d'aria
- Posizione COOL per getto d'aria tiepida
- Filtro asportabile
- Pulsante acceso/spento

Supporto da parete

- ELECTROSTOP - Interruttore differenziale $\leq 10\text{mA}$
- Presa rasoio 110-120V e 220-240V
- Trasformatore d'isolamento di sicurezza
- Interruttore automatico di sicurezza acceso/spento

Sèche-cheveux

- Commutateur de flux d'air: 2 positions
- Commutateur de chauffe: 3 positions
- 6 combinaisons de température/ventilation
- Position COOL à air tiède
- Filtre amovible
- Bouton poussoir on/off

Support mural

- ELECTROSTOP - Interrupteur différentiel $\leq 10\text{mA}$
- Prise rasoir 110-120V et 220-240V
- Transformateur de sécurité
- Interrupteur de sécurité on/off automatique

COLOURS: WHITE

CE

SWISS MADE

ElectroStop

EXCEL PROTECT 1600 - 1600W

MOD. 561.17/044.04



New

ON/OFF
PUSH
BUTTON
SECURITY

4X
SECURITY

Hairdryer

- Air flow control switch: 2 settings
- Air temperature control switch: 3 settings
- 6 air flow/ temperature combinations
- COOL air setting
- Removable filter
- On/Off push button

Wall holder

- ELECTROSTOP - Residual current device $\leq 10\text{mA}$
- Automatic On/Off safety switch

Haartrockner

- Luftstrom-Einstellung: 2-stufige Schiebetaste
- Lufttemperatur-Einstellung: 3-stufige Schiebetaste
- 6 Schaltkombinationen
- Abkühlstufe COOL
- Abnehmbarer Filter
- Ein/Aus-Druckschalter

Wandhalter

- ELECTROSTOP - Fehlerstrom-Schutzschalter $\leq 10\text{mA}$
- Automatischer Ein/Aus-Sicherheitsschalter

Asciugacapelli

- Tasto di regolazione del flusso d'aria: 2 posizioni
- Tasto di regolazione temperatura d'aria: 3 posizioni
- 6 combinazioni di temperatura/flusso d'aria
- Posizione COOL per getto d'aria tiepida
- Filtro asportabile
- Pulsante acceso/spento

Supporto da parete

- ELECTROSTOP - Interruttore differenziale $\leq 10\text{mA}$
- Interruttore automatico di sicurezza acceso/spento

Sèche-cheveux

- Commutateur de flux d'air: 2 positions
- Commutateur de chauffe: 3 positions
- 6 combinaisons de température/ventilation
- Position COOL à air tiède
- Filtre amovible
- Bouton poussoir on/off

Support mural

- ELECTROSTOP - Interrupteur différentiel $\leq 10\text{mA}$
- Interrupteur de sécurité on/off automatique

COLOURS: WHITE

CE

SWISS MADE

ElectroStop

EXCEL



EXCELLENCE 1600W

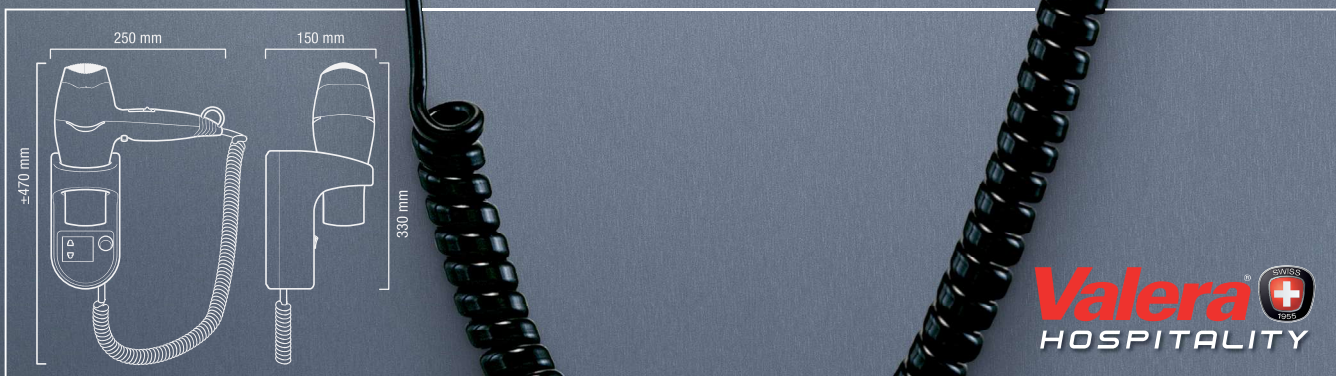

Valera[®] 
HOSPITALITY



Hairdryer

- Air flow control switch: 2 settings
- Air temperature control switch: 3 settings
- 6 air flow/temperature combinations
- COOL air setting
- Removable filter
- On/off push button

Wall holder

- On/off safety switch
- Shaver socket 110-120V and 220-240V
- Safety isolating transformer

Haartrockner

- Luftstrom-Einstellung: 2-stufige Schiebetaste
- Lufttemperatur-Einstellung: 3-stufige Schiebetaste
- 6 Schaltkombinationen
- Abkühlstufe COOL
- Abnehmbarer Filter
- Ein/Aus-Druckschalter

Wandhalter

- Ein/Aus-Sicherheitsschalter
- Rasiersteckdose 110-120V und 220-240V
- Sicherheits-Trenntransformator

Asciugacapelli

- Tasto di regolazione del flusso d'aria: 2 posizioni
- Tasto di regolazione temperatura dell'aria: 3 posizioni
- 6 combinazioni di temperatura/flusso d'aria
- Posizione COOL per getto d'aria tiepida
- Filtro asportabile
- Pulsante acceso/spento

Supporto da parete

- Interruttore acceso/spento di sicurezza
- Presa rasoio 110-120V e 220-240V
- Trasformatore d'isolamento di sicurezza

Sèche-cheveux

- Commutateur de flux d'air: 2 positions
- Commutateur de chauffe: 3 positions
- 6 combinaisons de température/ventilation
- Position COOL à air tiède
- Filtre amovible
- Bouton poussoir on/off

Support mural

- Interrupteur de sécurité on/off
- Prise rasoir 110-120V et 220-240V
- Transformateur de sécurité

COLOURS: WHITE SILVER



SWISS MADE

HAIRDRYERS for
HOTEL ROOMS



ACTION PROTECT

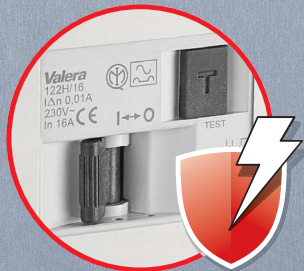

ElectroStop

CHROME DESIGN



Valera 
HOSPITALITY

ACTION PROTECT 1600 SHAVER - 1600W MOD. 542.06/044.06



New



ElectroStop

- Hairdryer**
- Slide switch: 2 air flow settings, 3 air temperature settings
 - COOL air setting
 - On/Off push button
 - Concentrator nozzle

- Wall holder**
- ELECTROSTOP - Residual current device ≤10mA
 - Shaver socket 110-120V and 220-240V
 - Safety isolating transformer
 - Automatic On/Off safety switch

- Haartrockner**
- Schiebetaste: 2 Lüfterstufen, 3 Temperaturstufen
 - Abkühlstufe COOL
 - Ein/Aus-Druckschalter
 - Ondulierdüse

- Wandhalter**
- ELECTROSTOP - Fehlerstrom-Schutzschalter ≤10mA
 - Rasiersteckdose 110-120V und 220-240V
 - Sicherheits-Trenntransformator
 - Automatischer Ein/Aus-Sicherheitsschalter

COLOURS: WHITE/ CHROME BLACK/CHROME **SWISS MADE**

- Asciugacapelli**
- Tasto di regolazione: 2 posizioni di flusso d'aria, 3 posizioni di temperatura d'aria
 - Posizione COOL per getto d'aria tiepida
 - Pulsante acceso/spento
 - Bocchetta
- Supporto da parete**
- ELECTROSTOP - Interruttore differenziale ≤10mA
 - Presa rasoio 110-120V e 220-240V
 - Trasformatore d'isolamento di sicurezza
 - Interruttore automatico di sicurezza acceso/spento

- Sèche-cheveux**
- Interrupteur à glissière: 2 positions de ventilation, 3 positions de chauffe
 - Position COOL à air tiède
 - Bouton poussoir on/off
 - Concentrateur d'air

- Support mural**
- ELECTROSTOP - Interrupteur différentiel ≤10mA
 - Prise rasoir 110-120V et 220-240V
 - Transformateur de sécurité
 - Interrupteur de sécurité on/off automatique

ACTION PROTECT 1600 SOCKET - 1600W MOD. 542.06/044.03



New



ElectroStop

- Hairdryer**
- Slide switch: 2 air flow settings, 3 air temperature settings
 - COOL air setting
 - On/Off push button
 - Concentrator nozzle

- Wall holder**
- ELECTROSTOP - Residual current device ≤10mA
 - Standard European socket 16 A
 - Automatic On/Off safety switch

- Haartrockner**
- Schiebetaste: 2 Lüfterstufen, 3 Temperaturstufen
 - Abkühlstufe COOL
 - Ein/Aus-Druckschalter
 - Ondulierdüse

- Wandhalter**
- ELECTROSTOP - Fehlerstrom-Schutzschalter ≤10mA
 - Schuko-Steckdose 16A
 - Automatischer Ein/Aus-Sicherheitsschalter

COLOURS: BLACK/ CHROME **SWISS MADE**

- Asciugacapelli**
- Tasto di regolazione: 2 posizioni di flusso d'aria, 3 posizioni di temperatura d'aria
 - Posizione COOL per getto d'aria tiepida
 - Pulsante acceso/spento
 - Bocchetta
- Supporto da parete**
- ELECTROSTOP - Interruttore differenziale ≤10mA
 - Presa standard europea 16A
 - Interruttore automatico di sicurezza acceso/spento

- Sèche-cheveux**
- Interrupteur à glissière: 2 positions de ventilation, 3 positions de chauffe
 - Position COOL à air tiède
 - Bouton poussoir on/off
 - Concentrateur d'air

- Support mural**
- ELECTROSTOP - Interrupteur différentiel ≤10mA
 - Prise européenne standard 16A
 - Interrupteur de sécurité on/off automatique

ACTION PROTECT 1600 - 1600W MOD. 542.06/044.04



New



ElectroStop

- Hairdryer**
- Slide switch: 2 air flow settings, 3 air temperature settings
 - COOL air setting
 - On/Off push button
 - Concentrator nozzle

- Wall holder**
- ELECTROSTOP - Residual current device ≤10mA
 - Automatic On/Off safety switch

- Haartrockner**
- Schiebetaste: 2 Lüfterstufen, 3 Temperaturstufen
 - Abkühlstufe COOL
 - Ein/Aus-Druckschalter
 - Ondulierdüse
 - Welldrahtheizelement SECURITY

- Wandhalter**
- ELECTROSTOP - Fehlerstrom-Schutzschalter ≤10mA
 - Automatischer Ein/Aus-Sicherheitsschalter

COLOURS: WHITE/ CHROME BLACK/CHROME **SWISS MADE**

- Asciugacapelli**
- Tasto di regolazione: 2 posizioni di flusso d'aria, 3 posizioni di temperatura d'aria
 - Posizione COOL per getto d'aria tiepida
 - Pulsante acceso/spento
 - Bocchetta
- Supporto da parete**
- ELECTROSTOP - Interruttore differenziale ≤10mA
 - Interruttore automatico di sicurezza acceso/spento

- Sèche-cheveux**
- Interrupteur à glissière: 2 positions de ventilation, 3 positions de chauffe
 - Position COOL à air tiède
 - Bouton poussoir on/off
 - Concentrateur d'air

- Support mural**
- ELECTROSTOP - Interrupteur différentiel ≤10mA
 - Interrupteur de sécurité on/off automatique

HAIRDRYERS for
HOTEL ROOMS

ACTION SUPER PLUS



CHROME DESIGN

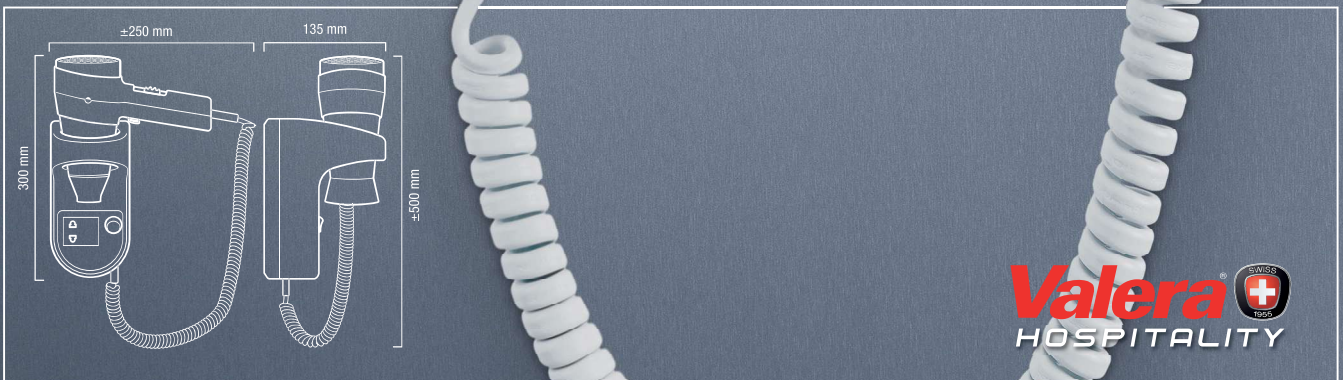

Valera 
HOSPITALITY



ACTION SUPER PLUS 1600 SHAVER - 1600W MOD. 542.06/032.05

Hairdryer

- Slide switch:
- 2 air flow settings,
- 3 air temperature settings
- COOL air setting
- On/off push button
- Concentrator nozzle

Wall holder

- On/Off safety switch
- Shaver socket 110-120V and 220-240V
- Safety isolating transformer

Haartrockner

- Schiebetaste:
- 2 Lüfterstufen,
- 3 Temperaturstufen
- Abkühlstufe COOL
- Ein/Aus-Druckschalter
- Ondulierdüse

Wandhalter

- Ein/Aus-Sicherheitsschalter
- Rasiersteckdose 110-120V und 220-240V
- Sicherheits-Trenntransformator

Asciugacapelli

- Tasto di regolazione:
- 2 posizioni di flusso d'aria,
- 3 posizioni di temperatura d'aria
- Posizione COOL per getto d'aria tiepida
- Pulsante acceso/spento
- Bocchetta

Supporto da parete

- Interruttore acceso/spento di sicurezza
- Presa rasoio 110-120V e 220-240V
- Trasformatore d'isolamento di sicurezza

Sèche-cheveux

- Interrupteur à glissière:
- 2 positions de ventilation,
- 3 positions de chauffe
- Position COOL à air tiède
- Bouton poussoir on/off
- Concentrateur d'air

Support mural

- Interrupteur de sécurité on/off
- Prise rasoir 110-120V et 220-240V
- Transformateur de sécurité

COLOURS: WHITE/CHROME SILVER/CHROME **MADE**



ACTION SUPER PLUS 1800 - 1800W MOD. 542.14/038A

Hairdryer

- Slide switch:
- 2 air flow settings,
- 3 air temperature settings
- COOL air setting
- On/off push button
- Concentrator nozzle

Wall holder

- On/Off safety switch

Haartrockner

- Schiebetaste:
- 2 Lüfterstufen,
- 3 Temperaturstufen
- Abkühlstufe COOL
- Ein/Aus-Druckschalter
- Ondulierdüse

Wandhalter

- Ein/Aus-Sicherheitsschalter

Asciugacapelli

- Tasto di regolazione:
- 2 posizioni di flusso d'aria,
- 3 posizioni di temperatura d'aria
- Posizione COOL per getto d'aria tiepida
- Pulsante acceso/spento
- Bocchetta

Supporto da parete

- Interruttore acceso/spento di sicurezza

Sèche-cheveux

- Interrupteur à glissière:
- 2 positions de ventilation,
- 3 positions de chauffe
- Position COOL à air tiède
- Bouton poussoir on/off
- Concentrateur d'air

Support mural

- Interrupteur de sécurité on/off

COLOURS: WHITE/CHROME BLACK/CHROME **MADE**

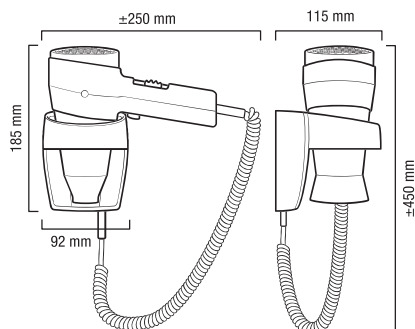

ACTION SUPER PLUS 1600 - 1600W MOD. 542.06/038A

- Same as mod. 542.14/038A, but **1600W**
- Wie Mod. 542.14/038A, jedoch **1600W**
- Come mod. 542.14/038A, ma **1600W**
- Comme mod. 542.14/038A, mais **1600W**

COLOURS: WHITE/CHROME BLACK/CHROME **MADE**

ACTION SUPER PLUS 1200 - 1200W MOD. 542.05/038A

- Same as mod. 542.14/038A, but **1200W**
- Wie Mod. 542.14/038A, jedoch **1200W**
- Come mod. 542.14/038A, ma **1200W**
- Comme mod. 542.14/038A, mais **1200W**

COLOURS: WHITE/CHROME BLACK/CHROME **MADE**



PREMIUM PROTECT

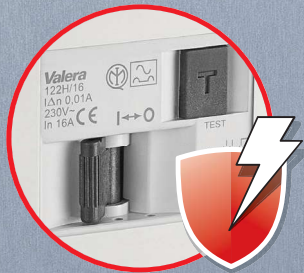

ElectroStop

CLASSIC DESIGN

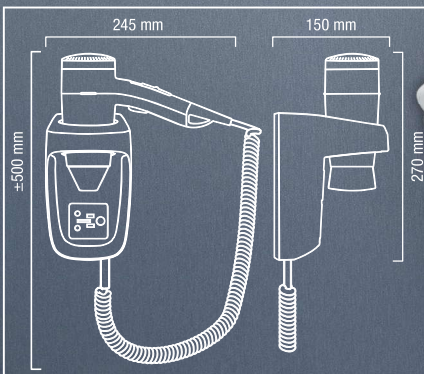

Valera 
HOSPITALITY

PREMIUM PROTECT 1200 SHAVER - 1200W MOD. 533.03/044.06



New



Hairdryer

- Slide switch: 2 air flow settings, 3 air temperature settings
- COOL air setting
- On/Off push button
- Concentrator nozzle

Wall holder

- ELECTROSTOP - RCD residual current device $\leq 10\text{mA}$
- Shaver socket 110-120V and 220-240V
- Safety isolating transformer
- Automatic On/Off safety switch

Haartrockner

- Schiebetaste: 2 Lüfterstufen, 3 Temperaturstufen
- Abkühlstufe COOL
- Ein/Aus-Druckschalter
- Ondulierdüse

Wandhalter

- ELECTROSTOP - Fehlerstrom-Schutzschalter $\leq 10\text{mA}$
- Rasiersteckdose 110-120V und 220-240V
- Sicherheits-Trenntransformator
- Automatischer Ein/Aus-Sicherheitsschalter

Asciugacapelli

- Tasto di regolazione: 2 posizioni di flusso d'aria, 3 posizioni di temperatura d'aria
- Posizione COOL per getto d'aria tiepida
- Pulsante acceso/spento
- Bocchetta

Supporto da parete

- ELECTROSTOP - Interruttore differenziale RCD $\leq 10\text{mA}$
- Presa rasoio 110-120V e 220-240V
- Trasformatore d'isolamento di sicurezza
- Interruttore automatico di sicurezza acceso/spento

Sèche-cheveux

- Interrupteur à glissière: 2 positions de ventilation, 3 positions de chauffe
- Position COOL à air tiède
- Bouton poussoir on/off
- Concentrateur d'air

Support mural

- ELECTROSTOP - Interrupteur différentiel $\leq 10\text{mA}$
- Prise rasoir 110-120V et 220-240V
- Transformateur de sécurité
- Interrupteur de sécurité on/off automatique

ElectroStop

COLOURS: WHITE



SWISS MADE

PREMIUM PROTECT 1200 - 1200W

MOD. 533.03/044.04



New



Hairdryer

- Slide switch: 2 air flow settings, 3 air temperature settings
- COOL air setting
- On/Off push button
- Concentrator nozzle

Wall holder

- ELECTROSTOP - RCD residual current device $\leq 10\text{mA}$
- Automatic On/Off safety switch

Haartrockner

- Schiebetaste: 2 Lüfterstufen, 3 Temperaturstufen
- Abkühlstufe COOL
- Ein/Aus-Druckschalter
- Ondulierdüse

Wandhalter

- ELECTROSTOP - Fehlerstrom-Schutzschalter $\leq 10\text{mA}$
- Automatischer Ein/Aus-Sicherheitsschalter

Asciugacapelli

- Tasto di regolazione: 2 posizioni di flusso d'aria, 3 posizioni di temperatura d'aria
- Posizione COOL per getto d'aria tiepida
- Pulsante acceso/spento
- Bocchetta

Supporto da parete

- ELECTROSTOP - Interruttore differenziale RCD $\leq 10\text{mA}$
- Interruttore acceso/spento di sicurezza automatico

Sèche-cheveux

- Interrupteur à glissière: 2 positions de ventilation, 3 positions de chauffe
- Position COOL à air tiède
- Bouton poussoir on/off
- Concentrateur d'air

Support mural

- ELECTROSTOP - Interrupteur différentiel $\leq 10\text{mA}$
- Interrupteur de sécurité on/off automatique

ElectroStop

COLOURS: WHITE



SWISS MADE

HAIRDRYERS for
HOTEL ROOMS



CLASSIC DESIGN



PREMIUM SMART 1600 SOCKET - 1600W MOD. 533.05/032.02



Hairdryer

- Slide switch:
 - 2 air flow settings,
 - 3 air temperature settings
- COOL air setting
- On/Off push button
- Concentrator nozzle

Wall holder

- On/Off safety switch
- Standard European socket 16A

Haartrockner

- Schiebetaste:
 - 2 Lüfterstufen,
 - 3 Temperaturstufen
- Abkühlstufe COOL
- Ein/Aus-Druckschalter
- Ondulierdüse

Wandhalter

- Ein/Aus-Sicherheitsschalter
- Schuko-Steckdose 16A

COLOURS: WHITE

Asciugacapelli

- Tasto di regolazione:
 - 2 posizioni di flusso d'aria,
 - 3 posizioni di temperatura d'aria
- Posizione COOL per getto d'aria tiepida
- Pulsante acceso/spento
- Bocchetta

Supporto da parete

- Interruttore acceso/spento di sicurezza
- Presa standard europea 16A

Sèche-cheveux

- Interrupteur à glissière:
 - 2 positions de ventilation,
 - 3 positions de chauffe
- Position COOL à air tiède
- Bouton poussoir on/off
- Concentrateur d'air

Support mural

- Interrupteur de sécurité on/off
- Prise européenne standard 16A



SWISS MADE

PREMIUM SMART 1200 SOCKET - 1200W MOD. 533.03/032.02



- Same as mod. 533.05/032.02, but **1200W**

- Come mod. 533.05/032.02, ma **1200W**

- Wie Mod. 533.05/032.02, jedoch **1200W**

- Comme mod. 533.05/032.02, mais **1200W**

COLOURS: WHITE



SWISS MADE

PREMIUM SMART 1600 SHAVER - 1600W MOD. 533.05/032.05



Hairdryer

- Slide switch:
 - 2 air flow settings,
 - 3 air temperature settings
- COOL air setting
- On/Off push button
- Concentrator nozzle

Wall holder

- On/Off safety switch
- Shaver socket 110-120V and 220-240V
- Safety isolating transformer

Haartrockner

- Schiebetaste:
 - 2 Lüfterstufen,
 - 3 Temperaturstufen
- Abkühlstufe COOL
- Ein/Aus-Druckschalter
- Ondulierdüse

Wandhalter

- Ein/Aus-Sicherheitsschalter
- Rasiersteckdose 110-120V und 220-240V
- Sicherheits-Trenntransformator

COLOURS: WHITE

Asciugacapelli

- Tasto di regolazione:
 - 2 posizioni di flusso d'aria,
 - 3 posizioni di temperatura d'aria
- Posizione COOL per getto d'aria tiepida
- Pulsante acceso/spento
- Bocchetta

Supporto da parete

- Interruttore acceso/spento di sicurezza
- Presa rasoio 110-120V e 220-240V
- Trasformatore d'isolamento di sicurezza

Sèche-cheveux

- Interrupteur à glissière:
 - 2 positions de ventilation,
 - 3 positions de chauffe
- Position COOL à air tiède
- Bouton poussoir on/off
- Concentrateur d'air

Support mural

- Interrupteur de sécurité on/off
- Prise rasoir 110-120V et 220-240V
- Transformateur de sécurité



SWISS MADE

PREMIUM SMART 1200 SHAVER - 1200W MOD. 533.03/032.05



- Same as mod. 533.05/032.05, but **1200W**

- Come mod. 533.05/032.05, ma **1200W**

- Wie Mod. 533.05/032.05, jedoch **1200W**

- Comme mod. 533.05/032.05, mais **1200W**

COLOURS: WHITE



SWISS MADE

PREMIUM



CLASSIC DESIGN



Valera 
HOSPITALITY



PREMIUM 1600 SUPER - 1600W

MOD. 533.05/038A

Hairdryer

- Slide switch:
- 2 air flow settings,
- 3 air temperature settings
- COOL air setting
- On/Off push button
- Concentrator nozzle

Wall holder

- On/Off safety switch

Haartrockner

- Schiebetaste:
- 2 Lüfterstufen,
- 3 Temperaturstufen
- Abkühlstufe COOL
- Ein/Aus-Druckschalter
- Ondulierdüse

Wandhalter

- Ein/Aus-Sicherheitsschalter

Asciugacapelli

- Tasto di regolazione:
- 2 posizioni di flusso d'aria,
- 3 posizioni di temperatura d'aria
- Posizione COOL per getto d'aria tiepida
- Pulsante acceso/spento
- Bocchetta

Supporto da parete

- Interruttore acceso/spento di sicurezza

Sèche-cheveux

- Interrupteur à glissière:
- 2 positions de ventilation,
- 3 positions de chauffe
- Position COOL à air tiède
- Bouton poussoir on/off
- Concentrateur d'air

Support mural

- Interrupteur de sécurité on/off

COLOURS: WHITE

Mod. dép.



SWISS MADE

PREMIUM 1200 SUPER - 1200W

MOD. 533.03/038A



- Same as mod. 533.05/038A, but **1200W**

- Come mod. 533.05/038A, ma **1200W**

- Wie Mod. 533.05/038A, jedoch **1200W**

- Comme mod. 533.05/038A, mais **1200W**

COLOURS: WHITE

Mod. dép.



SWISS MADE

PREMIUM 1600 - 1600W

MOD. 533.06/038A



Hairdryer

- On/Off push button
- 1 temperature/air flow setting
- Concentrator nozzle

Wall holder

- On/Off safety switch

Haartrockner

- Ein/Aus-Druckschalter
- 1 Temperatur-/Lüfterstufe
- Ondulierdüse

Wandhalter

- Ein/Aus-Sicherheitsschalter

Asciugacapelli

- Pulsante acceso/spento
- 1 posizione di temperatura/flusso d'aria
- Bocchetta

Supporto da parete

- Interruttore acceso/spento di sicurezza

Sèche-cheveux

- Bouton poussoir on/off
- 1 position de température/flux d'air
- Concentrateur d'air

Support mural

- Interrupteur de sécurité on/off

COLOURS: WHITE

Mod. dép.



SWISS MADE

PREMIUM 1200 - 1200W

MOD. 533.04/038A



- Same as mod. 533.06/038A, but **1200W**

- Come mod. 533.06/038A, ma **1200W**

- Wie Mod. 533.06/038A, jedoch **1200W**

- Comme mod. 533.06/038A, mais **1200W**

COLOURS: WHITE

Mod. dép.



SWISS MADE

PREMIUM 1100 - 1100W

MOD. 533.15/038B



- Same as mod. 533.06/038A, but **1100W**

- Come mod. 533.06/038A, ma **1100W**

Wall holder

- Connection to electrical mains without switch

Supporto

- Connessione alla rete elettrica senza interruttore

- Wie Mod. 533.06/038A, jedoch **1100W**

- Comme mod. 533.06/038A, mais **1100W**

Wandhalter

- Netzanschluss ohne Schalter

Support mural

- Connexion à l'alimentation électrique sans interrupteur

COLOURS: WHITE

Mod. dép.



SWISS MADE



SUPER COMPACT
DESIGN



Valera 
HOSPITALITY



EXECUTIVE 1200 SUPER - 1200W

MOD. 554.02/038A

Hairdryer

- Slide switch:
- 2 air flow/temperature settings
- On/Off push button
- Concentrator nozzle

Wall holder

- On/Off safety switch

Haartrockner

- Schiebetaste:
- 2 Temperatur/Luftstrom-Schaltkombinationen
- Ein/Aus-Druckschalter
- Ondulierdüse

Wandhalter

- Ein/Aus-Sicherheitsschalter

COLOURS: WHITE

Asciugacapelli

- Tasto di regolazione:
- 2 combinazioni di temperatura/flusso d'aria
- Pulsante acceso/spento
- Bocchetta

Supporto da parete

- Interruttore acceso/spento di sicurezza

Sèche-cheveux

- Interrupteur à glissière:
- 2 combinaisons de température/ventilation
- Bouton poussoir on/off
- Concentrateur d'air

Support mural

- Interrupteur de sécurité on/off



SWISS MADE

EXECUTIVE 1200 - 1200W

MOD. 554.01/038B



Hairdryer

- On/Off push button
- 1 temperature/air flow setting
- Concentrator nozzle

Wall holder

- Connection to electrical mains without switch

Haartrockner

- Ein/Aus-Druckschalter
- 1 Temperatur-/Lüfterstufe
- Ondulierdüse

Wandhalter

- Netzanschluss ohne Schalter

COLOURS: WHITE

Asciugacapelli

- Pulsante acceso/spento
- 1 posizione di temperatura/flusso d'aria
- Bocchetta

Supporto da parete

- Connessione alla rete elettrica senza interruttore

Sèche-cheveux

- Bouton poussoir on/off
- 1 positions de température/flux d'air
- Concentrateur d'air

Support mural

- Connexion à l'alimentation électrique sans interrupteur



SWISS MADE



PREMIUM DRAWER

HIDE-AWAY
DESIGN



Valera 
HOSPITALITY



PREMIUM 1600 DRAWER - 1600W

MOD. 533.05/033

Hairdryer

- Slide switch:
- 2 air flow settings,
- 3 air temperature settings
- COOL air setting
- On/off push button
- Concentrator nozzle

Drawer holder

- On/off safety switch with pilot lamp

Haartrockner

- Schiebetaste:
- 2 Lüfterstufen,
- 3 Temperaturstufen
- Abkühlstufe COOL
- Ein/Aus-Druckschalter
- Ondulierdüse

Halterung für Schublade

- Ein/Aus-Sicherheitsschalter mit Beleuchtung

Asciugacapelli

- Tasto di regolazione:
- 2 posizioni di flusso d'aria,
- 3 posizioni di temperatura d'aria
- Posizione COOL per getto d'aria tiepida
- Pulsante acceso/spento
- Bocchetta

Supporto da cassetto

- Interruttore luminoso acceso/spento di sicurezza

Sèche-cheveux

- Interrupteur à glissière:
- 2 positions de ventilation,
- 3 positions de chauffe
- Position COOL à air tiède
- Bouton poussoir on/off
- Concentrateur d'air

Support pour tiroir

- Interrupteur de sécurité on/off avec lampe témoin

COLOURS: WHITE

Mod. dép.



SWISS MADE



PREMIUM 1200 DRAWER - 1200W

MOD. 533.03/033

- Same as mod. 533.05/033, but **1200W**

- Come mod. 533.05/033, ma **1200W**

- Wie Mod. 533.05/033, jedoch **1200W**

- Comme mod. 533.05/033, mais **1200W**

COLOURS: WHITE

Mod. dép.



SWISS MADE





SWISS METAL MASTER LIGHT PUSH - 1200W

MOD. 584.03/P

Steel hairdryer with On/Off push button

- Metal body in chrome plated premium steel
- LONG-LIFE DC-Pro Motor
- 6 air flow/temperature combinations
- Ultra-narrow concentrator nozzle
- Removable metallic filter
- Spiral cable

Metall-Haartrockner mit Ein/Aus-Druckschalter

- Metallgehäuse aus verchromtem Premium-Stahl
- DC-Pro LONG-LIFE Motor
- 6 Temperatur/Luftstrom-Schaltkombinationen
- Extra schmale Ondulierdüse
- Abnehmbarer Metallfilter
- Spiralkabel

COLOURS: SILVER

Mod. dép.

Asciugacapelli in metallo con pulsante acceso/spento

- Corpo in acciaio cromato Premium
- Motore DC-Pro LONG-LIFE
- 6 combinazioni di temperatura/flusso d'aria
- Bocchetta ultra stretta
- Filtro metallico removibile
- Cordone spiralato

Sèche-cheveux en métal avec bouton poussoir on/off

- Corps en acier chromé Premium
- Moteur DC-Pro LONG-LIFE
- 6 combinaisons de température/ventilation
- Embout concentrateur ultra-fin
- Filtre métallique amovible
- Cordon spiralé



SWISS MADE

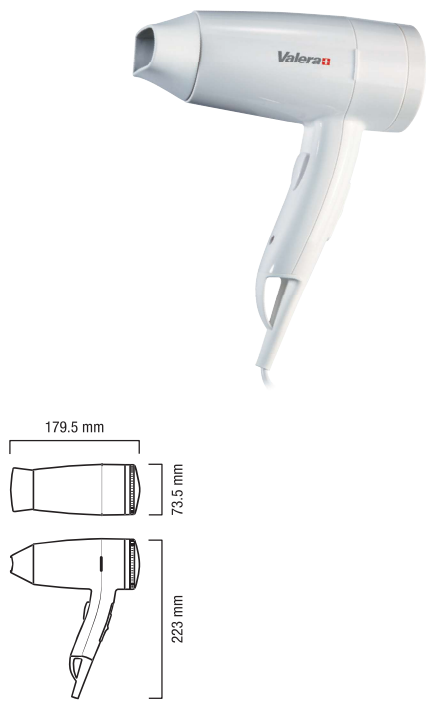

PREMIUM 1600 PUSH - 1600W

MOD. 533.05

Hairdryer with On/Off push button

- Slide switch:
 - 2 air flow settings,
 - 3 air temperature settings
- COOL air setting
- Concentrator nozzle
- Spiral cable

Haartrockner mit Ein/Aus-Druckschalter

- Schiebetaste:
 - 2 Lüfterstufen,
 - 3 Temperaturstufen
- Abkühlstufe COOL
- Ondulierdüse
- Spiralkabel

COLOURS: WHITE

Mod. dép.

Asciugacapelli con pulsante acceso/spento

- Tasto di regolazione:
 - 2 posizioni di flusso d'aria,
 - 3 posizioni di temperatura d'aria
- Posizione COOL per getto d'aria tiepida
- Bocchetta
- Cordone spiralato

Sèche-cheveux avec bouton poussoir on/off

- Interrupteur à glissière:
 - 2 positions de ventilation,
 - 3 positions de chauffe
- Position COOL à air tiède
- Concentrateur d'air
- Cordon spiralé



SWISS MADE



EXECUTIVE 1200 PUSH - 1200W

MOD. 554.02

Hairdryer with On/Off push button

- Slide switch:
 - 2 air flow/temperature settings
- Concentrator nozzle
- Spiral cable

Haartrockner mit Ein/Aus-Druckschalter

- Schiebetaste:
 - 2 Temperatur/ Luftstrom-Schaltkombinationen
- Ondulierdüse
- Spiralkabel

COLOURS: WHITE

Asciugacapelli con pulsante acceso/spento

- Tasto di regolazione:
 - 2 combinazioni di temperatura/flusso d'aria
- Bocchetta
- Cordone spiralato

Sèche-cheveux avec bouton poussoir on/off

- Interrupteur à glissière:
 - 2 combinaisons de température/ventilation
- Concentrateur d'air
- Cordon spiralé



SWISS MADE



EXCEL 1875 PUSH - 1875W

MOD. 561.22

Hairdryer with On/Off push button

- 6 air flow/temperature combinations incl. COOL air setting
- Removable filter
- Concentrator nozzle
- Spiral cable

Asciugacapelli con pulsante acceso/spento

- 6 combinazioni di temperatura/ flusso d'aria compresa la posizione COOL
- Filtro asportabile
- Bocchetta
- Cordone spiralato

Haartrockner mit Ein/Aus-Druckschalter

- 6 Temperatur/Luftstrom-Schaltkombinationen inkl Abkühlstufe COOL
- Abnehmbarer Filter
- Onduliertdüse
- Spiralkabel

Sèche-cheveux avec bouton poussoir on/off

- 6 combinaisons de température/ventilation compris la position COOL
- Filtre amovible
- Concentrateur d'air
- Cordon spiralé

COLOURS: WHITE



SWISS MADE

EXCEL 1600 PUSH - 1600W

MOD. 561.17

- Same as mod. 561.22, but **1600W**

- Come mod. 561.22, ma **1600W**

- Wie Mod. 561.22, jedoch **1600W**

- Comme mod. 561.22, mais **1600W**

COLOURS: WHITE



SWISS MADE

ACTION 1800 PUSH - 1800W

MOD. 542.14

Hairdryer with On/Off push button

- Slide switch:
- 2 air flow settings,
- 3 air temperature settings
- COOL air setting
- Concentrator nozzle
- Spiral cable

Asciugacapelli con pulsante acceso/spento

- Tasto di regolazione:
- 2 posizioni di flusso d'aria,
- 3 posizioni di temperatura
- Posizione COOL per getto d'aria tiepida
- Bocchetta
- Cordone spiralato

Haartrockner mit Ein/Aus-Druckschalter

- Schiebetaste:
- 2 Lüfterstufen,
- 3 Temperaturstufen
- Abkühlstufe COOL
- Onduliertdüse
- Spiralkabel

Sèche-cheveux avec bouton poussoir on/off

- Interrupteur à glissière:
- 2 positions de ventilation,
- 3 positions de chauffe
- Position COOL à air tiède
- Concentrateur d'air
- Cordon spiralé

COLOURS: WHITE/CHROME

BLACK/CHROME



SWISS MADE

ACTION 1600 PUSH - 1600W

MOD. 542.06

- Same as mod. 542.14, but **1600W**

- Come mod. 542.14, ma **1600W**

- Wie Mod. 542.14, jedoch **1600W**

- Comme mod. 542.14, mais **1600W**

COLOURS: WHITE/CHROME

BLACK/CHROME



SWISS MADE

ACTION 1200 PUSH - 1200W

MOD. 542.05

- Same as mod. 542.14, but **1200W**

- Come mod. 542.14, ma **1200W**

- Wie Mod. 542.14, jedoch **1200W**

- Comme mod. 542.14, mais **1200W**

COLOURS: WHITE/CHROME

BLACK/CHROME



SWISS MADE

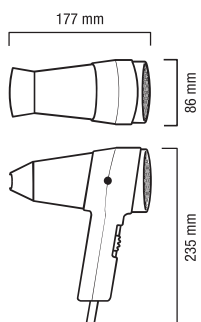
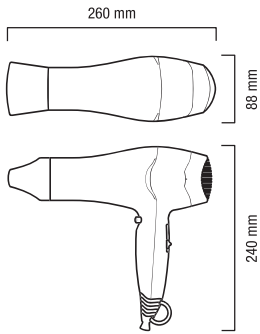

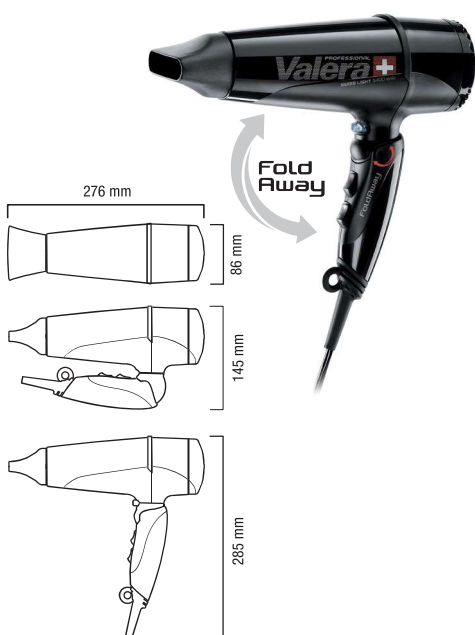

FOLD-AWAY 5400 IONIC TF - 2000W

MOD. SL 5400 TF

Ultra-light hairdryer

- Foldable handle
- Ions generator
- LONG-LIFE DC Motor
- Security thermal cutoff
- 6 air flow/temperature combinations
- Cool air button
- Hinged air inlet grille
- Concentrator nozzle
- SuperFlex cable 3 m

Ultraleichter Haartrockner

- Klappgriff
- Ionen-Generator
- LONG-LIFE DC Motor
- Thermosicherung
- 6 Temperatur/Luftstrom-Schaltkombinationen
- Abkühl Taste
- Lufteintrittsgitter mit Scharnier
- Ondulierdüse
- Super-Flex-Kabel 3 m

COLOURS: BLACK



Asciugacapelli ultra leggero

- Manico pieghevole
- Generatore di ioni
- Motore DC LONG-LIFE
- Termofusibile di sicurezza
- 6 combinazioni di temperatura/flusso d'aria
- Tasto aria tiepida
- Griglia di aspirazione incernierata
- Bocchetta
- Cordone SuperFlex 3 m

Sèche-cheveux ultraléger

- Poignée pliante
- Ionisateur
- Moteur DC LONG-LIFE
- Fusible thermique de sécurité
- 6 combinaisons de température/ventilation
- Bouton à air tiède
- Grille d'entrée d'air montée sur charnière
- Concentrateur d'air
- Câble SuperFlex 3 m



SWISS  MADE



EXCEL 2000 IONIC TF - 2000W

MOD. 561.08/I TF

Ultra-light hairdryer

- Ions generator
- Security thermal cutoff
- 6 air flow/temperature combinations incl. COOL air setting
- Concentrator nozzle
- Removable filter

Asciugacapelli ultra leggero

- Generatore di ioni
- Termofusibile di sicurezza
- 6 combinazioni di temperatura/ flusso d'aria compresa la posizione COOL
- Bocchetta
- Filtro asportabile

Ultraleichter Haartrockner

- Ionen-Generator
- Thermosicherung
- 6 Temperatur/Luftstrom-Schaltkombinationen inkl. Abkühlstufe COOL
- Ondulierdüse
- Abnehmbarer Filter

Sèche-cheveux ultraléger

- Ionisateur
- Fusible thermique de sécurité
- 6 combinaisons de température/ventilation comprise la position COOL
- Concentrateur d'air
- Filtre amovible

COLOURS: BLACK



SWISS MADE



EXCEL 1800 TF - 1800W

MOD. 561.19 TF

Ultra-light hairdryer

- With wall holder mod. 034
- Security thermal cutoff
- 6 air flow/temperature combinations
- Cool air button
- Concentrator nozzle
- Removable filter

Asciugacapelli ultra leggero

- Con supporto a muro mod. 034
- Termofusibile di sicurezza
- 6 combinazioni di temperatura/flusso d'aria
- Tasto aria tiepida
- Bocchetta
- Filtro asportabile

Ultraleichter Haartrockner

- Mit Wandhalter Mod. 034
- Thermosicherung
- 6 Temperatur/Luftstrom-Schaltkombinationen
- Abkühlstufe
- Ondulierdüse
- Abnehmbarer Filter

Sèche-cheveux ultraléger

- Avec support mural mod. 034
- Fusible thermique de sécurité
- 6 combinaisons de température/ventilation
- Bouton à air tiède
- Concentrateur d'air
- Filtre amovible

COLOURS: BLACK



SWISS MADE



UNIVERSAL

MOD. SXJ., SN., SL., 542., 561., 583., 584.

MOD. 040

- Universal wall holder for hairdryers
- Universeller Wandhalter für Haartrockner

- Supporto da parete universale per asciugacapelli
- Support mural universel pour sèche-cheveux



UNIVERSAL CHROME

MOD. 040/C

- Same as Mod. 040, but chrome plated
- Wie Mod. 040, jedoch verchromt

- Come Mod. 040, ma cromato
- Comme Mod. 040, mais chromé



JOLLY

MOD. SL., 561., 542., 554., 533.

MOD. 034

- Ring-shaped wall holder with cable locking device for hairdryer
- Ringförmiger Wandhalter für Haartrockner mit Kabelsperrvorrichtung

- Supporto da parete ad anello con dispositivo blocca cavo per asciugacapelli
- Support mural à anneau avec dispositif de blocage du fil pour sèche-cheveux



JOLLY CHROME

MOD. 034/C

- Same as Mod. 034, but chrome plated
- Wie Mod. 040, jedoch verchromt

- Come Mod. 034, ma cromato
- Comme Mod. 040, mais chromé

BLACK POUCH

MOD. B01

- Flannel pouch 300x400 mm
- Flanell-Aufbewahrungsbeutel 300x400 mm

- Sacchetto di protezione in flanella 300x400 mm
- Sachet de protection en flanelle 300x400 mm



Baros – Maldives



The finest hotels
in the world are equipped
with Valera hairdryers

Yas Marina Hotel – Abu Dhabi



ANGOLA

Epic Sana Luanda Hotels Luanda

ARMENIA

Republica Hotel Yerevan

AUSTRIA

Austria Trend Hotels
Eurothermen Resorts
Falkensteiner Hotels
Gruppe Arcotel
Hotel Sacher Salzburg
Hotel Sacher Vienna
Schick Hotels Vienna

BELGIUM

Hotel Crown Plaza Liege
Hotel Sheraton Bruxelles
Hotel Kempinski Brugge

BULGARIA

Flamingo Grand Hotel Albena
Kempinski Hotel Grand Arena Bansko
Barceló Royal Beach Sunny Beach
Duni Royal Resort Sozopol

CAPE VERDE

Hotel Riu Touareg Boa Vista

CHINA

Beijing Macao Swissotel Beijing
Hilton Beijing
The Hilton Beijing Capital Airport Beijing
Park Hyatt Beijing
Peninsula Palace Beijing
The Crowne Plaza Chengdu
Panda Garden Chengdu
Hilton Dalian
Kempinski Dalian
Radisson Plaza Hotel Hangzhou
Park Hyatt Shanghai
Renaissance Yangtze Hotel Shanghai
Sheraton Hua Ting Shanghai
The Portman Ritz-Carlton Shanghai
Marco Polo Shenzhen
The Langham Shenzhen
Kempinski Wuxi
Grand Hyatt Hong Kong
Hyatt Regency Shatin Hong Kong
ICON Hotel Hong Kong
JW Marriott Hong Kong
Langham Place Hotel Hong Kong
Mandarin Oriental Hotel Hong Kong
Marco Polo Hong Kong Hotel Hong Kong
Mira Moon Hong Kong
Regal Hotel Hong Kong
Sheraton Hotel Hong Kong
The Excelsior Hong Kong
The Intercontinental Hong Kong
The Mira Hong Kong
W Hotel Hong Kong
Grand Hyatt Macau
Grand Lisboa Macau
Sofitel Macau Macau
St. Regis Hotel Macau

CROATIA

Park Plaza Histria Pula
Falkensteiner Croatia Zadar
Double Tree by Hilton Zagreb

CYPRUS

Aeneas Resort & Spa Aya Napa
Atlantica Miramare Beach Limassol

CZECH REPUBLIC

Grand Hotel Pupp Karlovy Vary
Savoy Westend Karlovy Vary
Danubius Health Spa Marianske Lazne
Resort Nove Lazne
Grand Hotel Bohemia Prague
Hilton Prague Prague
Hotel U Prince Prague
Intercontinental Prague
Mandarin Oriental Prague
Occidental Praha Wilson Prague
Sheraton Prague

DENMARK

Phoenix Copenhagen
Tivolo Hotel Copenhagen

DOMINICAN REPUBLIC

Hotel Casa de Campo Resort La Romana

EGYPT

Hilton Green Plaza Alexandria
Fairmont Heliopolis Cairo Cairo
Intercontinental Pyramids Park Cairo
Le Meridien Pyramids Hotel Cairo
Movenpick Hotel Media City Cairo
Ramses Hilton Cairo
Sofitel EL Gezirah Hotel Cairo
Steigenberger El Tahrir Cairo
The Fairmont Nile City Cairo
Pyramisa Hotel & Casino Giza
Le Meridien Pyramids Hotel Giza
Helnan Dreamland Hotel Giza
Hilton Hurghada Plaza Hurghada
Le Meridien Luxor Hotel Luxor
Maritim Jolie Ville Luxor
Cleopatra Luxury Resort Sharm El Sheikh
Coral Sea Resort Hotel Sharm El Sheikh
Hilton Sharm Waterfalls Resort Sharm El Sheikh
Marriott Beach Resort Sharm El Sheikh
Radisson SAS Resort Sharm El Sheikh
Savoy Sharm El Sheikh
Sheraton Sharm El Sheikh
Heights Marriott Beach Resort Taba
Hilton Taba
Mövenpick Taba

ESTONIA

Baltic Hotel Imperial Tallin
Palace Tallin
Radisson Hotel Olümpia Tallin

FINLAND

Tallink Silja M/S Silja Ship

FRANCE

Mariott GoldenTulip
Louvre Hotels Group
Hotel Gray D'Albion Cannes
Disneyland® Hotel Paris
Hotel Edouard 7 Paris
Shangri-La Paris
Sofitel Strasbourg

GEORGIA

Marriott Hotel Tbilisi
Kabadoni Boutique Hotel Signhaghi

GERMANY

Best Western Parkhotel Erding
Steigenberger Grandhotel and Spa Heringsdorf (Usedom)
Hotel an der Oper München
Hotel Bayerischer Hof München
Vital Hotel Meiser Neustädtein

GREECE

Lagonissi Resort Athens
Kontokali Bay Kerkyra
Corfu Palace Korfu
Blue Domes Kos
Amirandes Resort Kreta
Elounda Beach Kreta
Robinson Club Kalimera Criti Kreta
La Marquise Rhodos
Makedonia Palace Thessaloniki

HOLLAND

Jolly Hotel Carlton Amsterdam

HUNGARY

Aquincum Hotel Budapest
Budapest Marriott Hotel Budapest
Intercontinental Budapest
Ramada Plaza Hotel Budapest
Spirit Hotel Thermal Spa Sarvar

INDIA

ITC Hotels Bengaluru
Grand Mercure Bengaluru
JW Marriott Bengaluru

Marriott Resort & Spa
Four Point Sheraton
Ajit Bhawan
Swissotel
Sahara Star Hotel
Taj Mahal
Le Meridien
Maurya Sheraton Hotel
Radisson Blu Plaza
Four Point Sheraton
Marriott Hotel
JW Marriott Mussoorie Walnut Grove Resort & Spa
Goa
Jaipur
Jodhpur
Kolkata
Mumbai
Mumbai
New Delhi
New Delhi
New Delhi
Pune
Pune
Uttarakhand

INDONESIA

Conrad Bali
Grand Hyatt Bali
Nikko Bali
J.W. Marriott Jakarta

IRAN

Dariush Grand Hotel Kish Island

ISRAEL

The David Citadel Hotel Jerusalem
The Crowne Plaza Hotel Tel Aviv

ITALY

Grand Hotel Piz Galin Andalo
Hotel Riz Forte dei Marmi
Adler Spa Resorts Gröden
Mirabell Alpenresidence Hafling
Garberhof Malles
Therme Meran Meran
Hotel ADLER DOLOMITI Ortisei
Alpin Garden Wellness Resort St. Christina
Ruzzini Palace Venice
Vigilius Mountain Resort Vigilijoch/Lana

JORDAN

Bristol Hotel Amman
Gand Hyatt Hotel Amman
Intercontinental Hotel Amman
Kempinski Amman
Le Meridien Amman, Aqaba
Le Royal Hotel Amman
Rotana Hotel Amman
Sheraton Hotel Amman, Dead Sea
Intercontinental Hotel Aqaba
Movenpick Resort Tala Bay Aqaba
Radisson SAS Hotel Aqaba
Crowne Plaza Hotel & Resort Dead Sea
Mövenpick Dead Sea
Mövenpick Nabatean Castle Petra

KUWAIT

Safir Airport Hotel Kuwait City
Hilton Resort Mangaf

LATVIA

Avalon Hotel Riga

LEBANON

Intercontinental Phoenicia Beirut
Lancaster Plaza Beirut
Le Royal Hotel & resort Beirut
Marriott Hotel Beirut
Metropolitan Hotels & Resorts Beirut
Radisson blu Beirut
Byblos Sur Mer Byblos
Veer Hotel & Resort Kaslik

MALAYSIA

LEGOLAND Hotel Johor bahru
Hyatt Regency Kinabalu Kota kinabalu, Sabah
Grand Hyatt Kuala Lumpur
Parkroyal Hotel Kuala Lumpur
The St Regis Resort Langkawi
Avani Gold Coast Resort Sepang

MALDIVES

Baros Maldives
Constance Hotel Experience

MAURITIUS

Hotel Intercontinental Mauritius Resort
Shanti Maurice A Nira Resort



Sheraton Hotel – Hong Kong



Burj al arab – Dubai



Hotel Kulm – Switzerland

MONTENEGRO

Hunguest Hotel Sun Resort Herceg Novi

MOROCCO

Hotel Mamounia Marrakech

NORWAY

Radisson Blu Park Hotel Oslo
Thron Hotel Opera Oslo
Thon Hotel Oslofjord
Best Western Tingvold Park Hotel Steinkjer

OMAN

Intercontinental Muscat
Shangri-La's Barr Al Jissah Resort Muscat

PHILIPPINES

Boracay Shangri-La Hotel Boracay Island
The Manila Peninsula Hotel Makaty City

POLAND

Copernicus Cracow
Niebieski Hotel Cracow
Gdansk Hotel Gdansk
Hotel Warszawianka Jachranka
Aquarius Kolobrzeg
Hotel Krasicki Lidzbark Warminski
Belweder Ulstron
Hotel Bristol Warsaw
Intercontinental Warsaw

PORTUGAL

Epic SANA Algarve Albufeira
Sheraton Algarve Hotel Albufeira
Dona Filipa & San Lorenzo
Golf Resort Almancil
Quinta do Lago Hotel Almancil
Praia D'El Rey Marriott
Golf & Beach Resort Amoreira
Suites Alba Resort & Spa Carvoeiro
Vale d' Oliveiras Quinta Resort & Spa Carvoeiro
Farol Design Hotel Cascais
Pestana Casino Park Funchal
Pestana Grand Ocean Resort Hotel Funchal
Montebelo Vista Alegre Ílhavo Hotel Ílhavo
Cascade Resort Lagos
Yellow Lagos Meia Praia Hotel Lagos
Epic SANA Lisboa Lisbon
Four Seasons Hotel Ritz Lisbon
Intercontinental Lisbon
Marriott Lisbon Lisbon
MYRIAD by SANA Hotels Lisbon
Palácio de Governador Hotel Lisbon
Longevity Wellness Resort Monchique
Real Marina Hotel & Spa Olhão
Vila Vita Parc Porches
Vilalara Thalassa Resort Porches
Le Meridien Penina Golf & Resort Portimão
HF Ipanema Park Porto
Martinho Beach Resort & Hotel Sagres
Estalagem do Sado Setúbal
Pestana Vila Sol Spa & Golf Resort Vilamoura
Douro Scala Hotel Vila Real

QATAR

Oryx Rotana Hotel Doha
W Hotel Doha

ROMANIA

Lotus Therm Spa & Luxury Resort Baile Felix
Hotel Monte-Nelly Bucharest

RUSSIA

Crown Plaza Moscow
Golden Ring Moscow
Izmaylovo Moscow
President Hotel Moscow
Radisson Royal- Ukraina Moscow
Moika 22 Kempinski St.Petersburg
Radisson Resort Zavidovo

SAUDI ARABIA

Coral International Al Khobar
Holiday Inn Hotel Half Moon Bay Al Khobar
Sheraton Dammam
Elaf Galeria Jeddah
Park Hyatt Hotel Jeddah

Dar Al Tawheed Intercontinental

Fairmont Makkah
Crown Plaza Al Khobar
Four Seasons Hotel Riyadh
Intercontinental Hotel Riyadh
Marriott Hotel Riyadh
Riyadh Palace Hotel Riyadh

SEYCHELLES

Constance Lemuria Resort Praslin Island

SINGAPORE

Capella
Fairmont
Four Seasons Hotel
Intercontinental
Mandarin Orchard
Mandarin Oriental
Marina Bay Sands
Marina Mandarin
Orchard Hotel
Raffles
Rasa Sentosa Resort
Shangri-la Hotel
St. Regis
Swissotel Merchant Court
Swissotel Stamford
The Fullerton Hotel
The Pan Pacific

SLOVAKIA

SHERATON Bratislava Hotel Bratislava
Tulip House Hotel Bratislava
Grand Hotel Permon Podbanské, Vysoké Tatry

SOUTH AFRICA

Radisson Cape Town
Hyatt Regency Johannesburg

SPAIN

Paradores de España
Hotel Barcelo Premium Asia Garden Alicante
Hotel Boutique Villa Venecia Alicante
Insotel Fenicia
Prestige Thalasso SpA Ibiza
Hotel Princesa Yaiza Lanzarote
Eco Resort Aqa San Blas Tenerife
Iberostar Antheia Hotel Tenerife
Hotel Hilton Buenavista Toledo

SWEDEN

Elite Plaza Hotel Gothenburg
Radisson Blue Royal Viking Stockholm

SWITZERLAND

Arosa Kulm Hotel Arosa
Grand Hotel Tschuggen Arosa
Castello del Sole Ascona
Eden Roc Ascona
Hotel Giardino Bern
Bellevue Palace Bern
Seehof Davos
Waldhaus Flims Mountain Resort & Spa Flims
Hotel Anglettere Genève
Hotel Le Mirador Kempinski Genève
Intercontinental Hotel Genève
Mandarin Oriental Genève
President Wilson Hotel Genève
Grand Hotel Park Gstaad
Grandhotel Bellevue Gstaad
Palace Hotel Gstaad
Grand Hôtel Les Endroit La Chaux-de-Fonds
Villa Castagnola Lugano
Chateau Gütsch Luzern
Schweizerhof Luzern
The Hotel Luzern
Le Mirador Kempinski Mont-Pèlerin
Fairmont Le Palace Montreux
Kronenhof Pontresina
Badrutt's Palace St. Moritz
Hotel Kulm St. Moritz
W Hotel Verbier
Grand Hotel du Lac Vevey
The Omnia Zermatt
Atlantis by Giardino Zürich
Hotel Baur au Lac Zürich
Hyatt Zürich

TAIWAN

Hotel Royal Taipei
Nikko Hotel International Taipei

THAILAND

Amari Watergate Hotel Bangkok
Best Western Sukhumvit Bangkok
Conrad Hotel Bangkok
Grand Hyatt Erawan Bangkok
Hansar Bangkok Bangkok
Hyatt HuaHin Bangkok
Mandarin Oriental Bangkok
Metropolitan Bangkok
Shangrila Bangkok Bangkok
Siam Kempinski Hotel Bangkok
Sofitel So Bangkok
Swissotel Bangkok
The Westin Grande Sukhumvit Bangkok
Urbana Sathorn Hotel Bangkok
Four Seasons Chaing Mai
Four Seasons Koh Samui
Conrad Samui Koh Samui Island
Cape Dara Beach Front Hotel Pattaya
Maikhow Hotel Phuket Phuket Island
Le Meridien Baan
Taling Ngam Samui

TURKEY

Crowne Plaza Hotel Ankara
Cornelia Diamond Resort Belek
Marriott Asia Hotel Istanbul
Marriott Polat Renaissance Istanbul
Ramada Istanbul
Ritz Carlton Istanbul
Swissotel The Bosphorus Istanbul
Hilton Izmir
Ramada Hotel Konya
Bodrum Kempinsky Hotel Mugla
Sheraton Grand Samsun Samsun

UAE

Hilton Corniche Abu Dhabi
Park Rotana Abu Dhabi
Royal Meridien Abu Dhabi
Shangri-La Abu Dhabi
Sheraton Abu Dhabi
Sofitel Abu Dhabi
Yas Viceroy Hotel Abu Dhabi
Ajman Kempinsky Ajman
Hilton Ras Al Khaimah
Atlantis-Palm Jumeirah Dubai
Burj Al Arab Dubai
Conrad Hilton Dubai
Crown Plaza Sheik Zayed Road Dubai
Fairmont Palm Jumeirah Dubai
Hilton Jumeirah Dubai
Jumeirah Beach Club & Hotel Dubai
Jumeirah Emirates Towers Dubai
Kempinski
Mall of the Emirates Dubai
Raffles Dubai
Renaissance Dubai
Sheraton Hotels & Towers Dubai
The Address Dubai Mall Dubai
Westin Dubai
Hilton Fujairah
Hilton Sharjah

UKRAINE

Grand Hotel Ukraine Dnepropetrovsk
Donbass Palace Donetsk
Hyatt Kiev
Intercontinental Kiev
Opera Hotel Kiev
Premier Palace Kiev

UNITED KINGDOM

Premier Inn Hotels
Summerlodge Hotel Dorchester
Queens Hotel Leeds
Hilton Stansted London
Marriott Park Lane London
Park Plaza Westminster Bridge London
Celtic Manor Hotel Newport

YEMEN

Hotel Mövenpick Sana'a

HANDY

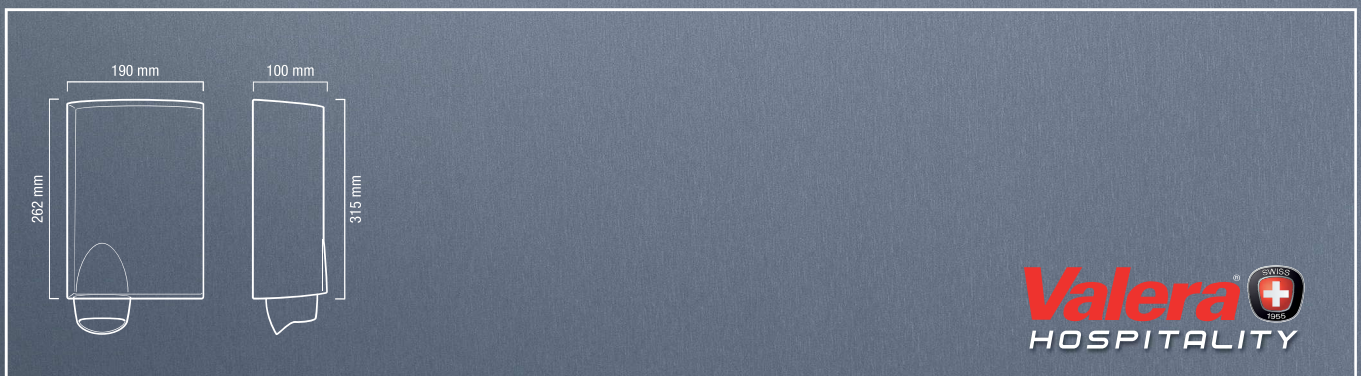



Powerful and compact automatic hand dryer

- Long life motor AC Heavy Duty
- Automatic on/off switching through infrared sensor
- Safety timer
- Easy wall-mounting without opening the appliance
- 2 possibilities of electrical wiring: direct connection to electrical mains (hardwire), connection with plug (softwire)
- Fixation screws and screw anchors incl.

Leistungsstarker und automatischer Kompakt-Händetrockner

- Long-Life Motor AC Heavy Duty
- Automatische Einschaltung durch Infrarot-Näherungsschalter
- Sicherheits-Zeitschalter
- Praktische Wandmontage ohne das Gerät öffnen zu müssen
- 2 Anschlussmöglichkeiten: Elektrischer Festanschluss, Direkter Steckeranschluss
- Einschl. Schrauben und Dübel zur Wandbefestigung

Potente e compatto asciugamani automatico

- Motore a lunga durata AC Heavy Duty
- Accensione automatica tramite sensore a infrarossi
- Timer di sicurezza
- Pratico montaggio a muro senza necessità di aprire l'apparecchio
- 2 possibilità di allacciamento a rete: diretto a cavo di rete che esce dal muro (hardwire), alla presa tramite cavo con spina (softwire)
- Completo di tasselli + viti per il fissaggio a muro

Sèche-mains automatique, puissant et compact

- Moteur longue durée AC Heavy Duty
- Allumage automatique par capteur à infrarouges
- Temporisateur de sécurité
- Montage au mur pratique sans ouverture de l'appareil
- 2 possibilités de raccordement au réseau électrique: direct par un câble d'alimentation relié à un boîtier de raccordement mural, à une prise électrique par câble avec fiche
- Jeu complet de chevilles + vis pour fixation au mur

COLOURS: WHITE



SWISS  MADE

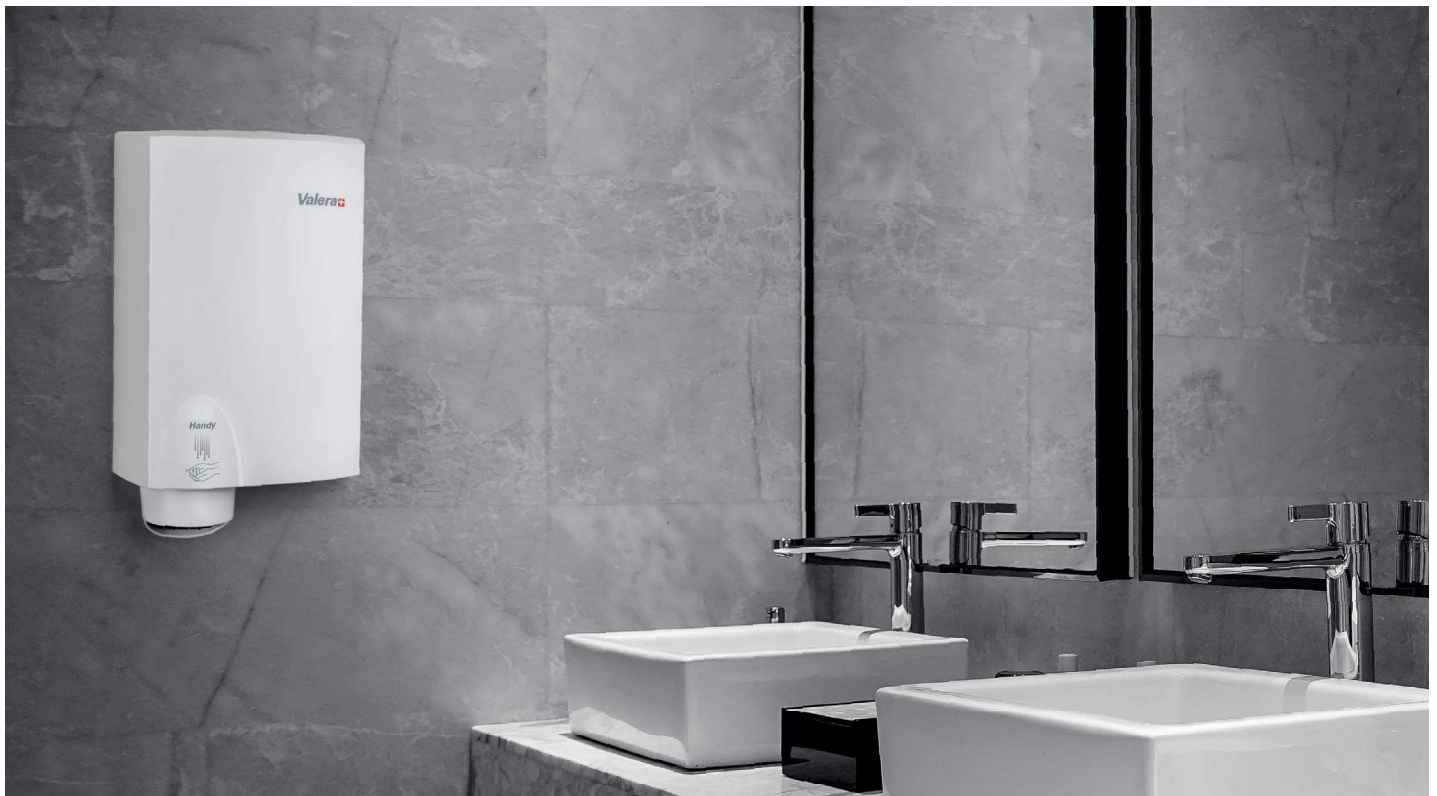

MAGNIFYING MIRRORS AND SOAP DISPENSERS



**PROXIMITY
SENSOR**
AUTOMATIC LIGHT
ACTIVATION
ENERGY SAVING



Valera
HOSPITALITY



New



Wall-mounted magnifying mirror with automatic LED lighting

- Automatic light activation through proximity sensor
- LED lighting 100-240 V, 50-60 Hz
- 3x magnifying mirror
- Arm length 180 mm
- Full pivotal adjustment
- Material: brass
- Finishing: chrome
- Mirror: Ø 216 mm
- Hard wire application
- Degree of protection: IP 44

Specchio ingranditore da parete con illuminazione LED automatica

- Attivazione automatica della luce tramite sensore di prossimità
- Lampade LED 100-240 V, 50-60 Hz
- Specchio ingranditore 3x
- Lunghezza braccio 180 mm
- Completamente orientabile
- Materiale: ottone
- Finitura: cromo
- Specchio: Ø 216 mm
- Versione cablata
- Grado di protezione: IP 44

Wandmontierter Vergrößerungsspiegel mit automatischer LED-Beleuchtung

- Automatische Lichtaktivierung durch Näherungssensor
- LED-Beleuchtung 100-240 V, 50-60 Hz
- 3-fach-Vergrößerungsspiegel
- Schwenkarm: Länge 180 mm
- Komplett schwenkbar
- Material: Messing
- Oberfläche: Chrom
- Spiegel: Ø 216 mm
- Fest verdrahtet
- Schutzgrad: IP 44

Miroir agrandisseur mural avec éclairage LED automatique

- Activation automatique de la lumière par capteur de proximité
- Éclairage LED 100-240 V, 50-60 Hz
- Miroir agrandisseur 3x
- Bras: longueur 180 mm
- Entièrement orientable
- Matériel: laiton
- Finition: chrome
- Miroir: Ø 216 mm
- Application câblée
- Degré de protection: IP 44



CE

OPTIMA LIGHT ONE



Wall mounted, LED-lighted magnifying mirror

- LED lighting 100-240 V, 50-60 Hz
- On/Off switch
- 3x magnifying mirror
- Arm length 180 mm
- Full pivotal adjustment
- Material: brass
- Finishing: chrome plated
- Mirror: Ø 216 mm
- Hard wire application
- Degree of protection: IP 44

Specchio ingranditore a LED da parete

- Lampade LED 100-240 V, 50-60 Hz
- Interruttore On/Off
- Specchio ingranditore 3x
- Lunghezza braccio 180 mm
- Completamente orientabile
- Materiale: ottone
- Finitura: cromo
- Specchio: Ø 216 mm
- Versione cablata
- Grado di protezione: IP 44

LED-beleuchteter Vergrößerungsspiegel mit Wandhalterung

- LED-Beleuchtung 100-240 V, 50-60 Hz
- Ein/Aus-Schalter
- 3-fach-Vergrößerungsspiegel
- Schwenkarm: Länge 180 mm
- Komplett schwenkbar
- Material: Messing
- Oberfläche: Chrom
- Spiegel: Ø 216 mm
- Fest verdrahtet
- Schutzgrad: IP 44

Miroir agrandisseur éclairé LED à fixation murale

- Éclairage à LED 100-240 V, 50-60 Hz
- Interrupteur On/Off
- Miroir agrandisseur 3x
- Bras: longueur 180 mm
- Entièrement orientable
- Matériel: laiton
- Finition: chrome
- Miroir: Ø 216 mm
- Application câblée
- Degré de protection: IP 44

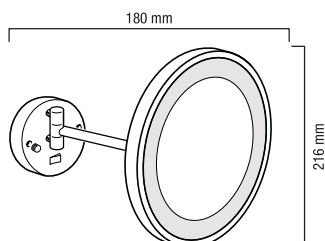

CE



OPTIMA CLASSIC

MOD. 207.01

Wall-mounted double sided magnifying mirror

- Plain mirror + 4x magnifying mirror
- Twin arm: extended length 330 mm
- Full pivotal adjustment
- Material: Brass
- Finishing: chrome
- Mirror: Ø 200 mm

Specchio ingranditore bifacciale da parete

- Specchio normale + specchio ingranditore 4x
- Braccio doppio: lunghezza braccio esteso 330 mm
- Completamente orientabile
- Materiale: ottone
- Finitura: cromo
- Specchio: Ø 200 mm

Vergrößerungsspiegel mit Wandhalterung

- Normaler Spiegel + 4-fach-Vergrößerungsspiegel
- Doppelter Gelenkarm: Gesamtlänge 330 mm
- Komplet schwenkbar
- Material: Messing
- Oberfläche: Chrom
- Spiegel: Ø 200 mm

Miroir agrandisseur à fixation murale

- Miroir normal + miroir agrandisseur 4x
- Double bras: longueur 330 mm
- Entièrement orientable
- Matériel: laiton
- Finition: chrome
- Miroir: Ø 200 mm

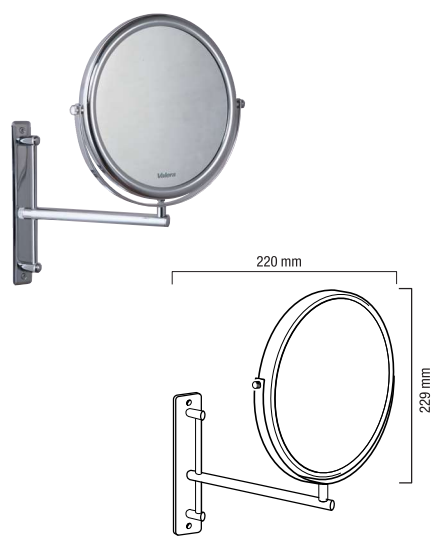

OPTIMA BAR

MOD. 207.00

Wall-mounted double sided magnifying mirror

- Plain mirror + 3x magnifying mirror
- Arm length 220 mm
- Bar length 155 mm
- Bar and full pivotal adjustment
- Material: steel
- Finishing: chrome
- Mirror: Ø 229 mm

Specchio ingranditore bifacciale da parete

- Specchio normale + specchio ingranditore 3x
- Lunghezza braccio 220 mm
- Lunghezza barra 155 mm
- Regolabile in altezza e completamente orientabile
- Materiale: acciaio
- Finitura: cromo
- Specchio: Ø 229 mm

Vergrößerungsspiegel mit Wandhalterung

- Normaler Spiegel + 3-fach-Vergrößerungsspiegel
- Schwenkarm: Länge 220 mm
- Wandstange: Länge 155 mm
- Höhenverstellbar und komplett schwenkbar
- Material: Stahl
- Oberfläche: Chrom
- Spiegel: Ø 229 mm

Miroir agrandisseur à fixation murale

- Miroir normal + miroir agrandisseur 3x
- Bras: longueur 220 mm
- Barre: longueur 155 mm
- Se règle en hauteur et est entièrement orientable
- Matériel: acier
- Finition: chrome
- Miroir: Ø 229 mm

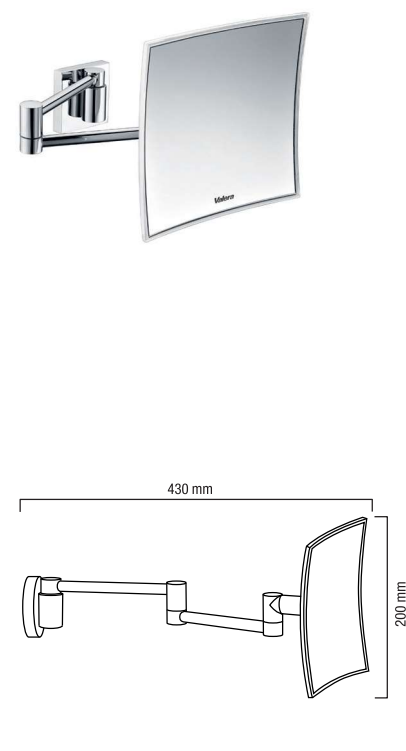

ESSENCE SQUARE

MOD. 207.08



Wall-mounted magnifying mirror

- 5x magnifying mirror 200 x 200 mm
- Safety glass: avoids injury in case of crash
- Twin arm: folded length 139 mm, extended length 430 mm
- Adjustable joints for durable smooth and precise movements
- Material: brass
- Finishing: chrome plating with superior durability
- Frame Tritan™ by Eastman: extra shock resistant, grey metallized with transparent outer edge

Specchio ingranditore da parete

- Specchio ingranditore 5x – 200 x 200 mm
- Vetro di sicurezza: evita lesioni in caso di rottura
- Braccio doppio: lunghezza 139 mm (piegato), 430 mm (esteso)
- Snodi regolabili per movimenti dolci e precisi di lunga durata
- Materiale: ottone
- Finitura: cromatura di resistenza superiore
- Cornice Tritan™ by Eastman: extra resistente agli urti, grigio metallizzato con bordo esterno trasparente

Vergrößerungsspiegel mit Wandhalterung

- 5-fach-Vergrößerungsspiegel 200 x 200 mm
- Sicherheitsglas: verhindert Verletzungen bei Bruch
- Doppelter Gelenkarm: eingeklappt 139 mm, ausgezogen 430 mm lang
- Regulierbare Gelenke für dauerhaft geschmeidige und präzise Beweglichkeit
- Material: Messing
- Oberfläche: höchst widerstandsfähige Chrombeschichtung
- Rahmen aus Tritan™ by Eastman: extra schlagfest, grau metallisiert mit transparenter Außenkante

Miroir agrandisseur à fixation murale

- Miroir agrandisseur 5x ; 200 x 200 mm
- Verre de sécurité pour éviter des blessures en cas d'accident
- Double bras: longueur repliée 139 mm, longueur étendue 430 mm
- Raccords réglables pour des mouvements fluides et précis de longue durée
- Matériel: laiton
- Finition: revêtement en chrome avec durabilité supérieure
- Cadre Tritan™ by Eastman: résistant aux chocs, gris métallisé avec bord extérieure transparente

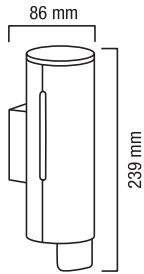
**Wall-mounted soap dispenser**

- Patented inner pump (Made in Sweden) for long time smooth performance with precise 2 ml dosage, comfortable and eco-friendly
- Vandal-proof structure
- Diameter 70 mm, capacity 350 ml
- Tube length 206 mm, total length 239 mm
- Depth from the wall: 86 mm
- Material: zinc alloy (die casting)
- Material inner basin: Tritan™ by Eastman
- Finishing: chrome plating with superior durability

Seifenspender mit Wandhalterung

- Patentierte Pumpe (hergestellt in Schweden) für dauerhaft geschmeidige und präzise 2 ml-Dosierung, komfortabel und umweltfreundlich
- Vandalensichere Struktur
- Durchmesser 70 mm, Füllmenge 350 ml
- Rohrlänge 206 mm, Gesamtlänge 239 mm
- Abstand von der Wand: 86 mm
- Material: Zinklegierung (Druckguss)
- Material Innenrohr: Tritan™ by Eastman
- Oberfläche: höchst widerstandsfähige Chrombeschichtung

Erogatore di sapone da parete

- Pompa interna brevettata (Made in Sweden) per prestazioni regolari con un dosaggio preciso di 2 ml, confortevole ed eco-friendly
- Struttura anti-vandalismo
- Diametro 70 mm, capienza 350 ml
- Lunghezza del tubo 206 mm, totale 239 mm
- Profondità dalla parete: 86 mm
- Materiale: lega di zinco (pressofusione)
- Materiale serbatoio interno: Tritan™ by Eastman
- Finitura: cromatura di resistenza superiore

Distributeur de savon à fixation murale

- Pompe interne breveté (fabriqué en Suède) pour performances de longue durée, avec dosage de précision de 2 ml, confortable et respectueux de l'environnement
- Structure anti-vandalisme
- Diamètre 70 mm, capacité 350 ml
- Longueur du tube 206 mm, totale 239 mm
- Profondeur depuis le mur: 86 mm
- Matériel: alliage de zinc (moulage sous pression)
- Matériel bassin intérieur: Tritan™ by Eastman
- Finition: revêtement en chrome avec durabilité supérieure

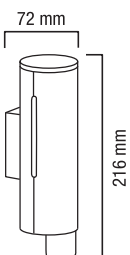
**Wall-mounted soap dispenser**

- Patented inner pump (Made in Sweden) for long time smooth performance with precise 2 ml dosage, comfortable and eco-friendly
- Vandal-proof structure
- Diameter 55 mm, capacity 190 ml
- Tube length 182 mm, total length 216 mm
- Depth from the wall: 72 mm
- Material: zinc alloy (die casting)
- Material inner basin: Tritan™ by Eastman
- Finishing: chrome plating with superior durability

Seifenspender mit Wandhalterung

- Patentierte Pumpe (hergestellt in Schweden) für dauerhaft geschmeidige und präzise 2 ml-Dosierung, komfortabel und umweltfreundlich
- Vandalensichere Struktur
- Durchmesser 55 mm, Füllmenge 190 ml
- Rohrlänge 182 mm, Gesamtlänge 216 mm
- Abstand von der Wand: 72 mm
- Material: Zinklegierung (Druckguss)
- Material Innenrohr: Tritan™ by Eastman
- Oberfläche: höchst widerstandsfähige Chrombeschichtung

Erogatore di sapone da parete

- Pompa interna brevettata (Made in Sweden) per prestazioni regolari con un dosaggio preciso di 2 ml, confortevole ed eco-friendly
- Struttura anti-vandalismo
- Diametro 55 mm, capienza 190 ml
- Lunghezza del tubo 182 mm, totale 216 mm
- Profondità dalla parete: 72 mm
- Materiale: lega di zinco (pressofusione)
- Materiale serbatoio interno: Tritan™ by Eastman
- Finitura: cromatura di resistenza superiore

Distributeur de savon à fixation murale

- Pompe interne breveté (fabriqué en Suède) pour performances de longue durée, avec dosage de précision de 2 ml, confortable et respectueux de l'environnement
- Structure anti-vandalisme
- Diamètre 55 mm, capacité 190 ml
- Longueur du tube 182 mm, totale 216 mm
- Profondeur depuis le mur: 72 mm
- Matériel: alliage de zinc (moulage sous pression)
- Matériel bassin intérieur: Tritan™ by Eastman
- Finition: revêtement en chrome avec durabilité supérieure





Ligo Electric S.A. Via Ponte Laveggio, 9 CH 6853 Ligornetto/Mendrisio (Switzerland)



Ligo Electric S.A.
Via Ponte Laveggio, 9
CH 6853 Ligornetto/Mendrisio
Switzerland
Tel. +41-91-6416620
Fax +41-91-6473055
e-mail info@ligo.com
www.valera.com

SWISS  MADE